

MOTORTRONICS

Solid State AC Motor Control

RX Series
Digital
Motor Protection Relay
5 – 2000A

**Advanced Installation,
Operation and Programming
Manual**



Table of Contents

RX Series Digital Motor Protection Relay 18 – 2000A

| | | | Page |
|--|---|---|------|
| Chapter 1: Introduction | 1.1 | General Description | 1 |
| | 1.2 | Sizes and Ratings | 4 |
| Chapter 2 - Installation | 2.1 | Receiving and Unpacking | 5 |
| | 2.2 | Choosing a Location | 5 |
| | 2.3 | Initial Unit Inspection | 5 |
| | 2.4 | SERVICE WARNING! | 6 |
| | 2.5 | Mounting and Cleaning | 6 |
| | 2.6 | Terminations | 7 |
| | 2.7 | Remote Keypad Mounting | 7 |
| | 2.8 | Dimensions | 8 |
| Chapter 3 - Motor Overload Protection | 3.1 | Solid State Overload Protection | 9 |
| | 3.2 | NEMA Class Trip Curves | 11 |
| Chapter 4 – Connections | 4.1 | Line Power Connections | 13 |
| | 4.2 | Control Connections | 16 |
| Chapter 5 – Programming | 5.1 | Introduction | 20 |
| | 5.2 | Digital Interface | 20 |
| | 5.3 | Display Modes | 21 |
| | 5.4 | Program Mode | 22 |
| | 5.4.5 | Fault Mode | 25 |
| | 5.5 | The RX Function List | 28 |
| | 5.6 | Function Descriptions | 34 |
| | 5.6.1 | Motor and Overload Functions | 34 |
| | 5.6.2 | Current Protections | 37 |
| | 5.6.2.a | Ground Fault Protection | 39 |
| | 5.6.3 | Voltage Protections..... | 40 |
| | 5.6.4 | Phase & Frequency Protections | 42 |
| | 5.6.5 | Motor Power Protections | 44 |
| | 5.6.6 | Lockouts / Inhibits..... | 46 |
| | 5.6.7 | Output Relays..... | 47 |
| | 5.6.8 | Motor Running Detection..... | 48 |
| | 5.6.9 | Process Timer/Time Clock Control. | 48 |
| | 5.6.10 | Communications | 49 |
| 5.6.11 | External Input..... | 50 | |
| 5.6.12 | System Settings | 50 | |
| 5.6.13 | Auto Reset and Auto Restart..... | 54 | |
| 5.6.14 | 16 Fault History and Statistical Data.. | 56 | |
| 5.6.17 | Relay 1 Fail Safe Programming..... | 60 | |
| 5.6.18 | Test settings and Miscellaneous.... | 60 | |
| Chapter 6 - Start-up | 6.1 | Basic Startup | 61 |
| | 6.2 | Start-up Check List | 62 |
| Chapter 7 - Fault Conditions | 7.1 | Fault Codes and Numbers | 63 |
| Appendices | | | |
| | | Appendix A: Parameter Lock / User Password Instructions | 66 |
| | | Appendix B: Process Control Timer Functions | 68 |
| | | Appendix C: Relay Settings Record | 76 |
| | | Warranty Information | 81 |

Chapter 1 - Introduction

1.1 General Description

The **RX Series** is a digitally programmable solid state motor protection relay. The **RX Series** features an advanced solid state overload relay, but provides much more than that for protection your motor and load. Designed to be versatile, it can be used in any configuration of 3 phase motor controller, including Across the Line (DOL), Reversing, 2 speed, electro-mechanical Reduced Voltage, Wye-Delta (Star-Delta) and Solid State Soft starters. The **RX Series** includes a programming keypad to use in setting operating parameters for the ideal starting and protection features, plus easy to understand diagnostic LEDs. Built-in Metering features can reduce the amount of separate components necessary for complete motor monitoring. An integrated Batch Process Timer and Time Clock Controller can be used for automated applications. The **RX Series** can accept control power anywhere from 85 – 265VAC without adjustments or settings and can use a dry contact input for Start / Stop control. Line voltage can be directly input up to 600V, or PTs can be used for up to 15kV motors. Current can be directly monitored up to 75A, or up to 1200A through external CTs.

1.1.1 Advanced Motor Protection Features

| | |
|---|---|
| Thermal Model Electronic Overload Protection | A sophisticated Thermal Model of the motor operation is created in the microprocessor to accurately track all starting, stopping and running conditions to provide maximum motor protection. |
| Retentive Thermal Memory | Overload circuit retains thermal condition of the motor regardless of control power status. Unit uses real time clock to adjust for off time. |
| Two Stage Overload Curves | Starting: Programmable for Class 5 or 10 Run: Programmable for Class 5 through 30 when "At-Speed" is detected. Programmable Run Detection: Auto or Auto / Timed Auto Method: $I > 150\% \text{ FLA} \times \text{SF}$, then $I < 100\% \text{ FLA} \times \text{SF}$ Auto / Timed: 1 – 180 seconds or Auto, whichever occurs first |
| Overload Reset | Manual (default) or automatic Dynamic Reset Tracking. Overload will not reset until thermal capacity available in the motor is enough for a successful restart. Relay learns and retains this information by monitoring previous successful starts. |
| Acceleration Protection | Acceleration Time Limit: 0 – 300 seconds For protection against mechanical problems or incomplete sequence on Reduced Voltage Starters. Stall Detection Trip Level: 100 – 600% FLA with 1 – 20 second delay. |
| Current Protection | Over Current Trip Level: 50 - 300% of motor FLA Under Current Trip Level: 10 –90 % of motor FLA Current Imbalance Trip Level: 5 - 30% Imbalance in any two phases Peak (short circuit) Current Trip: 800 – 1400% FLA Current Trip Delays: 1 -20 seconds |

1.1.1 Advanced Motor Protection Features (continued)

| | |
|--|--|
| Voltage Protection | Over Voltage Trip Level: 1 – 10% of Line Voltage Under Voltage Trip Level: 1 – 20% of Line Voltage Separate levels for Start and Run modes Voltage Imbalance Trip Level: 1 – 30% Phase Difference Voltage Trip Delays: 1 – 20 seconds |
| Phase Protection | Phase Loss Trip: Any phase current less than 20% of FLA setting Phase Rotation Trip: ABC, ACB or insensitive. Over Frequency Trip: 1 – 10Hz programmed frequency Under Frequency Trip: 1 – 10Hz programmed frequency Phase Protection Trip Delays: 1 -20 seconds |
| Equipment Ground Fault Protection | Type: Residual Current Trip Range: 5 – 90% of unit CT ratio Trip Delay: 1 – 60 seconds |
| Power Protection | Motor kW Trip Settings: Over / Under Trip or Alarm Under kW Trip Level: 20 – 100% of calculated motor kW kW Trip Delay: 1 – 9999 minutes PF Trip Setting: Lead, Lag or Lead/Lag, Normal or Reversed current direction PF Trip Level: 0.01 – 1.0 (cos. θ) |
| Starting Inhibit Protection | Coast Down (Back Spin) Lockout: Coast Down Time Range: 1 – 60 minutes Starts-per-hour Lockout: 1 – 10 successful starts per hour Minimum Time between Starts Lockout: 1 – 60 minutes between start attempts |
| Restart Delay | Sequential Start Feature for restarting delay after a power outage. 1-999 seconds after a power loss |
| Auto Reset | Can be programmed to attempt resetting after selected faults (12 settings) 0 – 10 Attempts, 2 minutes delay between attempts |

1.1.2 Control Features

| | |
|---|--|
| Motor Control | 2 Programmable Output Relays: 1 form C (SPDT), 1 form A (SPST), programmable to 30 functions 22 Trip functions, 4 Inhibit functions, 3 status functions and 1 Control function 1 External Input for external Trip or Start command. |
| Process Timer (2 modes) | Minimum Batch Timer: Runs until timer expires Permissive Run Timer: Runs only during specified times Time Range: 0 - 9999 minutes |
| Real Time Clock (RTC) Controller | 24/7 Time Clock Controller, works with Process Timer for run time Time Range: 1-24 hours Cycle Setting: 1- 7 days per week Event Settings: 1 - 7 start events per day |

1.1.3 Metering Features

| | |
|--|--|
| Current Metering | A, B, C phases individually or Average of all three phases Ground Fault Current |
| Voltage Metering | A-B, B-C or C-A phase voltage Average of all three phases |
| Power Metering | Motor kW (or MW) Motor kVA (or MVA) Motor kVAR or (MVAR) Motor Power Factor Leading (inductive) or Lagging (capacitive) indication |
| Phase Metering | Current Imbalance percentage Voltage Imbalance percentage Rotation Sequence Frequency |
| Real Time Clock Based Metering and Use Statistics | Motor Remaining Thermal Capacity Thermal Capacity to Reset Restart Delay Time after a power failure Coast Down Inhibit Time Time Between Starts Inhibit Time Process Timer Elapsed Time 24hr Time Clock Controller Time kWH (or MWH) power usage Motor Running Time (Elapsed Time Meter): 0 – 9,999,999.9 hrs. Motor Run Cycle Counter: 0 – 99,999,999 cycles |

1.1.4 Electrical Ratings

| | |
|---------------------------------|---|
| Type of Load: | Three phase AC induction motors |
| AC Supply Voltage: | Direct Input: 208 - 600VAC PT Input: .6 – 15kV (customer supplied PTs, 120V secondary) Tolerance: ±10% Frequency: Programmable for 50 or 60Hz |
| Power Ratings: | Direct Input: 1 – 75A Amps CT Input: 75 – 1200A using optional or customer supplied external CTs with 5A secondary |
| Phase Rotation | Operates with any phase sequence (insensitive) Programmable rotation trip ABC / ACB |
| Ambient Condition Design | Operating Temperature: 0° to 50 °C (32° to 122°F) Humidity: 5 - 95% relative Altitude: 0 - 3300 ft. (1000m) above sea level without derating |
| Control Power | 85 - 265VAC (customer supplied), no adjustments necessary |
| Inputs | 1 Dry (voltage free) contact input for Start or External Trip Uses 6VDC from an internal power supply |
| 2 Programmable Outputs | 1 each Form A (SPST), Fail Safe (configurable), 10A 250VAC, resistive, also rated 1/3HP (10.0 LRA) at 120VAC 1 each Form C (SPDT),: 5 Amps, 250VAC max. (1200VA) resistive Can be programmed for 30 functions, with trip delays Relay Test: Energize (force) either relay or both. |
| Approvals | UL Listed, Canadian UL (cUL) Listed CE Approved |

1.2 Sizes and Ratings

The Motortronics **RX Series** protection relays are current rated. Max. Amp ratings are for continuous duty and must not be exceeded. Always check the motor nameplate FLA and Service Factor to ensure proper sizing.

Each size has an adjustable range of current from 50% to 100% of the unit max. amp rating. Motors smaller than the lowest setting can be accommodated by using Primary Turns (see section 4.1.2 for details).

| Model Number | Current Range (direct reading) | Current Range (using Primary Turns) |
|----------------|--------------------------------|-------------------------------------|
| | Min. - Max. | Min. - Max. |
| RX-5-P | 2.5 - 5 | 1 – 2.5 (5 turns max.) |
| RX-40-P | 20 -40 | 10 – 20 (4 turns max.) |
| RX-75-P | 38 - 75 | --- |

Table 1.2: RX Series Sizes

The RX-5-P is designed to also be used with external CTs for motors with FLA ratings beyond the 75A limit of a stand-alone relay. See Chapter 4 for additional details.

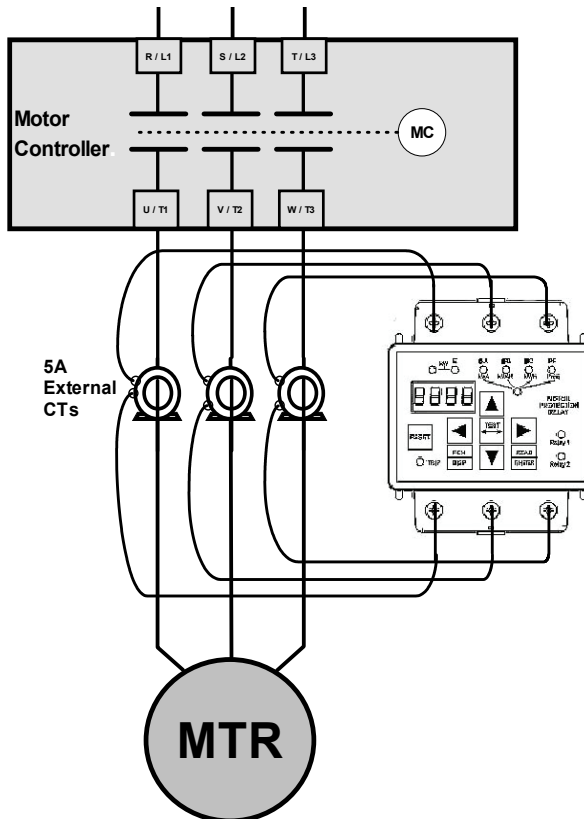

Figure 1.2: RX-5-P used with external CTs for larger motors

Chapter 2 - Installation

2.1 Receiving and Unpacking

Upon receipt of the product, you should immediately do the following:

- Carefully unpack the unit from the shipping carton and inspect it for shipping damage (if damaged, notify the freight carrier and file a claim within 15 days of receipt).
- Verify that the model number on the unit matches your purchase order.
- Confirm that the ratings sticker on the unit matches or is greater than the motor's HP and current rating.

2.2 Choosing a Location

Proper location of the **RX Series** is necessary to achieve specified performance and normal operation lifetime. The **RX Series** should always be installed in an area where the following conditions exist:

- Ambient operating temperature:
Panel (open chassis) unit: 0 to 50°C (32 to 122°F)
Enclosed unit: 0 to 40°C (32 to 104°F)
- Protected from rain, moisture and direct sun.
- Humidity: 5 to 95% non-condensing
- Free from metallic particles, conductive dust and corrosive gas
- Free from excessive vibration (below 0.5G)
- Units must be mounted in the appropriate type of enclosure.

2.3 Initial Unit Inspection

Make a complete visual check of the unit for damage that may have occurred during shipping and handling. Do not attempt to continue installation or start up the unit if it is damaged.

- Check for loose mechanical assemblies or broken wires which may have occurred during transportation or handling. Loose electrical connections will increase resistance and cause the unit to function improperly.
- Prior to beginning the installation, verify that the motor and **RX Series** unit are rated for the proper amperage and voltage.



2.4 SERVICE WARNING!

Do not service equipment with voltage applied! The unit can be the source of fatal electrical shocks! To avoid shock hazard, disconnect main power and control power before working on the unit. Warning labels must be attached to terminals, enclosure and control panel to meet local codes. Use Lock Out tags such as the one shown when servicing equipment.

2.5 Mounting and Cleaning

The RX Series is designed to snap onto standard duty DIN rail, or to mount directly to a panel with #8 screws (4mm). When drilling or punching holes in an enclosure containing an RX Series relay, cover the electrical assembly to prevent metal filings from becoming lodged in areas which can cause clearance reduction or actually short out electronics. After work is complete, thoroughly clean, vacuum the area, and re-inspect the unit for foreign material.

2.5.1 Clearances

Make sure there is sufficient clearance all around the unit for cooling, wiring and maintenance purposes. To conserve panel space, the **RX Series** was designed for close clearances. A minimum clearance of 1" (25 mm) on all sides is necessary to maximize effective airflow and cooling. Keep in mind that these are minimums. Wiring may require more clearance, particularly on the bottom.

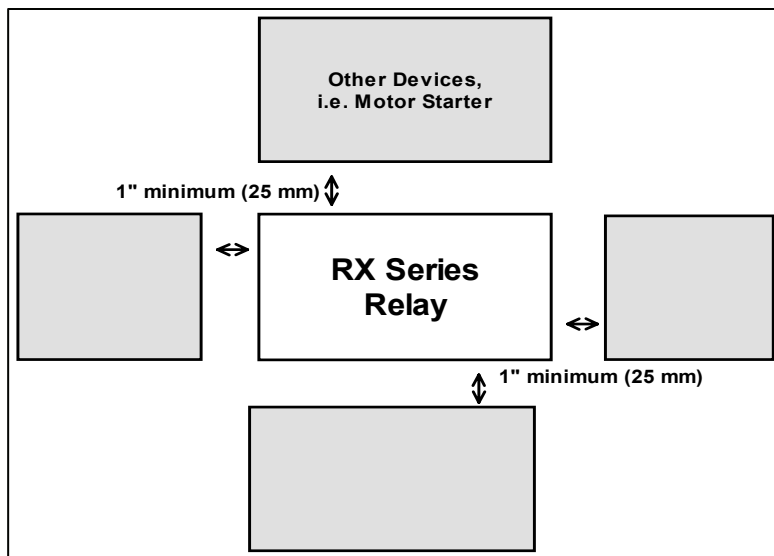

Figure 2.5: RX minimum mounting clearances



WARNING!

Remove all sources of power before cleaning the unit.

In dirty or contaminated atmospheres, the unit should be cleaned on a regular basis to ensure proper cooling. Do not use any chemicals to clean the unit. To remove surface dust use clean, dry compressed air only, 80 to 100 psi. A high quality, dry paintbrush is helpful to loosen up the dust prior to using compressed air on the unit. Do not use wire brushes or other conductive cleaning materials

2.6 Terminations

All line and control power terminations are to be made to plated saddle clamp terminals located on each unit. Motortronics recommends using crimp-on terminals wherever practical. Motor current conductors can feed through the built-in CT holes in the base of the relay.

The RX-5-P also comes with a Line-Load Power Terminal block that permits separate Line and Load power connections to be made with up to 12ga wire. This unit can be removed to provide access to the feed-through CT holes if desired.

Note: All wiring must be sized according to local code standards.

2.7 Remote Keypad Mounting

The keypad / operator interface unit can be remotely mounted up to 6' (1.8 meters) away from the relay, i.e. on the enclosure door. A remote mounting kit is not necessary, only a keypad seal gasket (only necessary for NEMA 12 / IP65 enclosures) is needed and a standard DB-9 connection cable (computer serial cable). Cables can also be made by the user with standard DB-9 connectors, Male for the keypad, Female for the base unit. The keypad can be mounted using 4 small #6 (M3) screws (customer supplied) and a 7/8" (22mm) hole to accommodate the DB-9 connector.

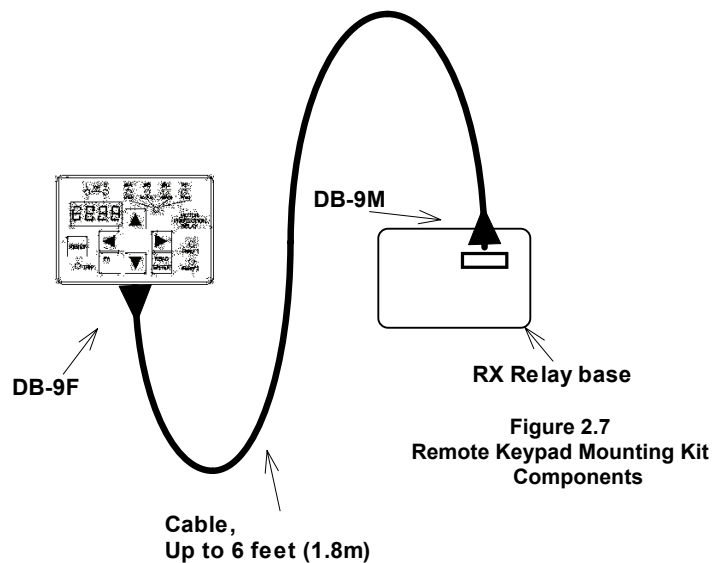
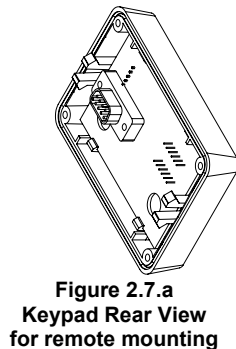

2.8 Dimensions

Note:
Drawing shown is the RX-5-P with Line-
Load Termination Adaptor.

For Feed- through versions, use this
dimension.

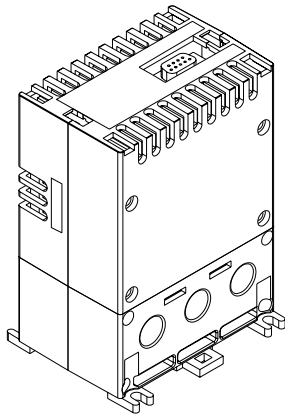

Figure 2.8.a: Feed-Through base unit example.

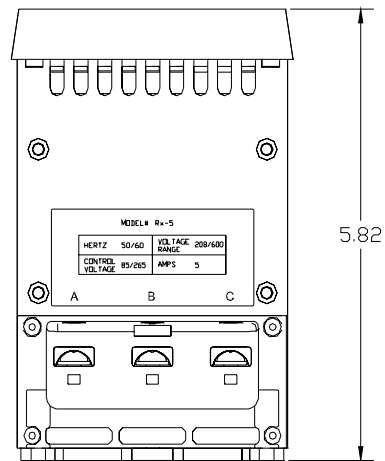
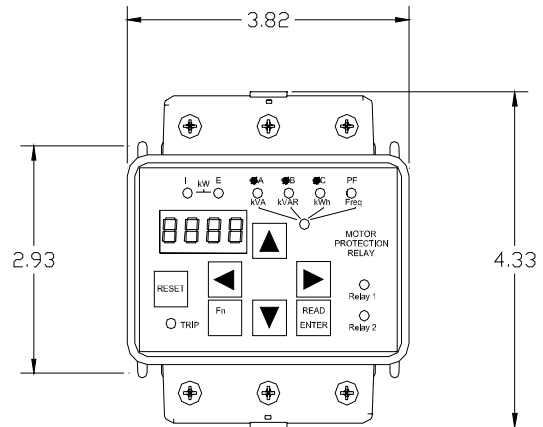
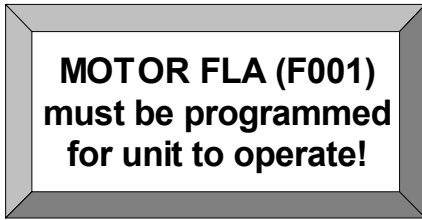

Figure 2.8: RX Dimensions

Chapter 3 - Motor Overload Protection



3.1 Solid State Overload Protection

The **RX Series** Relay provides true U.L. listed I²t Thermal Overload Protection as a built-in function of the main digital processor for maximum motor protection. It simulates the tripping action of a bi-metallic overload relay, with the accuracy and repeatability of a digital control system. It is adjustable over a wide range and can be easily programmed for different trip curves.

3.1.1 Thermal Memory

The **RX Series** microprocessor uses a sophisticated “Thermal Register” in the digital memory to keep track of motor heating and cooling over time regardless of the relay’s power status. By using non-volatile memory, the **RX Series** does not “forget” that the motor has been running even if power to the relay is turned off and back on. Continuous overload protection is provided based on the true thermal condition of the motor.

3.1.2 Thermal Capacity

The Thermal Register is displayed as a percentage. This percentage is the motor’s remaining thermal capacity. The percentage value begins at 100, showing that the motor is cool (has 100% of its capacity available). As the motor heats up or moves toward an overload condition, the percentage begins to drop. The Thermal Capacity is derived from the programmed motor nameplate Full Load Amps (FLA) in Function F001, the Service Factor rating in Function F002, and the Overload Trip Class in Functions F003 and F004. Setting these functions to the proper values provides maximum protection and eliminates nuisance tripping.

Examples:



100% Thermal Capacity remaining at rest



57% Thermal Capacity remaining after starting (43% used)

The Remaining Thermal Capacity can be viewed by using the UP or DOWN arrow keys when in the Status Display mode. From the default Phase A Current screen (dot on right side), press the UP arrow key to display **[H100]** meaning there is 100% of the Thermal Capacity (H = Heat capacity) remaining in the motor. After starting or running, the motor will use this capacity and the display will show a lower number. For example, after a cold start, the display may read **[H065]** which indicates that the motor has 65% of its thermal capacity remaining (35% used). The Status Display screens cycle back to the beginning, so the Down arrow keys can get to this display as well.

3.1.2.a Motor Full Load (FLA) Setting

Use Function F001 to enter motor FLA as indicated on the motor nameplate. (Do not calculate for service factor, this is programmed separately in F002).

Note:

All **RX Series** relays are shipped from the factory with F001 set to a default value of 0000. If F001 is left at the factory default, the unit will not operate. If the user attempts to start the **RX Series** without entering the motor nameplate FLA, the relay will Fault and the display will read “**nFLA**” (no Full Load Amps).



3.1.3 Disabling the Overload Protection

The Overload Protection feature can be disabled if necessary. When using external devices such as Motor Protection Relays or when the **RX Series** is use only for other features, this feature can be disabled to prevent conflicts with other overload protection devices.. To disable the Overload Protection function, use F005.

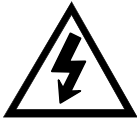

WARNING!

Do NOT disable Overload Protection unless another Thermal Overload Protection device exists in the circuit for all three phases. Running a motor without Overload Protection presents serious risk of motor damage or fire.

- **3.1.3.a Manual Reset**

The factory default setting is Manual Reset. This means that when the Overload Trip is activated, the starter cannot be restarted without pressing the Reset key. The Overload Trip will not reset until the motor cools down (see 3.1.3.d). The Manual Reset function is also “trip free”. Holding in the Reset key will not prevent the Overload Trip from activating and protecting the motor.



- **Note:**

When the Overload Trip activates, the Overload LED will glow solid. When the motor cools down, the LED will begin to flash, indicating that the Overload Trip can be reset.

- **3.1.3.b Automatic Reset**

If Automatic Reset is necessary, change from Manual Reset to Automatic Reset by using Function F005. (See Section 5 for details). In this mode, a 3-wire control circuit will be capable of restart when the **RX Series** has reset itself after the cool down period.

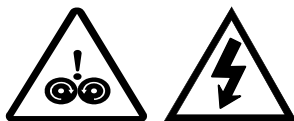

WARNING!

Two-wire control systems may restart without warning when Auto Reset of the overload protection is selected. Extreme caution should be exercised. To prevent automatic restarting with 2-wire control systems, use external interlocking to provide sufficient warning and safety to operators. A Warning Label similar to that shown below (and the one provided in the packet with this manual) must be located where visible (on the starter enclosure and/or the driven equipment) as required by local code.

**WARNING: MOTOR CONNECTED TO THIS EQUIPMENT
MAY START AUTOMATICALLY WITHOUT WARNING**

▪ **3.1.3.d Dynamic Reset Capacity**

The **RX Series** includes the ability to dynamically track the Thermal Capacity needed for a successful restart after an overload trip. It averages the Thermal Capacity consumed in the previous three successful starts, and calculates a Thermal Capacity to Start (viewed in Function **F086**). After tripping on Overload, the Thermal Register must have regained the amount recorded in F086 before a Reset will be allowed. If the display reads [**Inh**] when attempting to reset an overload trip, it is indicating that the relay is **Inhibited** from being reset.

Refer to details of Function F071 for information on emergency override of lockouts such as this.

3.2 NEMA Class Trip Curves

NEMA Class trip curves are based on a common tripping point of 600% of motor Full Load Amps (FLA). Curves vary by the amount of time before the unit trips. As an example, a Class 20 curve will trip in 20 seconds at 600% of FLA. The factory default setting of Class 10 will trip in 10 seconds at 600% of FLA.

3.2.1 Dual Overload Trip Curves

The **RX Series** Soft Relay provides two separate Overload Trip Protection Curves, one for starting and one for running conditions. The relay's At-Speed detection circuit determines when the motor has reached full speed (see Fn F049, section 5.6.8). When the At-Speed condition is reached, the overload trip curve will shift from the Start to the Run level, as programmed in Functions F003 and F004. See Section 5.6.1 for programming details.

3.2.2 Starting Overload Trip Curve

During the start mode, Overload Trip Curves are selectable from NEMA Class 5 through Class 20 only. The default setting of Class 10 allows protection for the overload capacity of the soft relay as well as the motor. Use a higher Trip Class only if nuisance tripping occurs with the default setting.

3.2.3 Running Overload Curve

During the Run mode, Overload trip curves are selectable from NEMA Class 5, 10, 15, 20, 25, and 30. Program the appropriate curve according to the characteristics of your motor and load.

3.2.4 Overload Trip Curve Chart

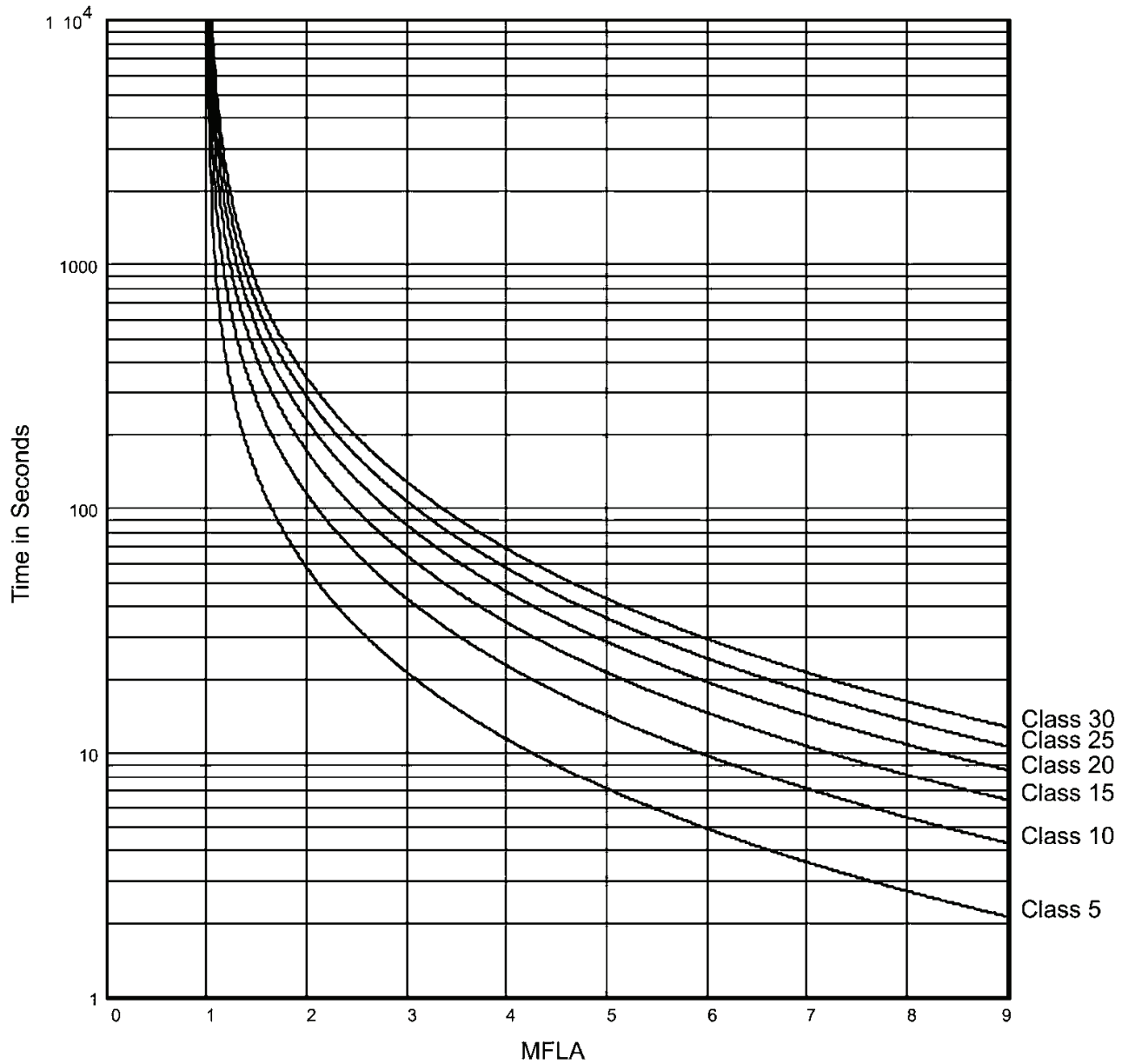

Note: Factory default setting is Class 10 for both Start and Run Overload Protection

Figure 3.2.4: RX Series Overload Trip Curves

Chapter 4 – Connections

4.1 Line Power Connections

Connect appropriately sized power conductors to the base unit input terminals marked L1, L2, L3 (R, S, T for IEC users) underneath the keypad. These will be for Line Voltage Sensing, not for the motor load (see below), but should be fuse protected for 5A max. Avoid routing power wires over the display.

4.1.1 Motor Power Connections

Motor power connections differ on different sizes.

On the RX-5-P, the user has 2 choices; Separate Line and Load connections to terminals on the relay base, or Feed-Through wiring.

Use the Separate Line and Load connections when the motor is small enough (<5A FLA) to be connected directly to the terminal block screws on the base.

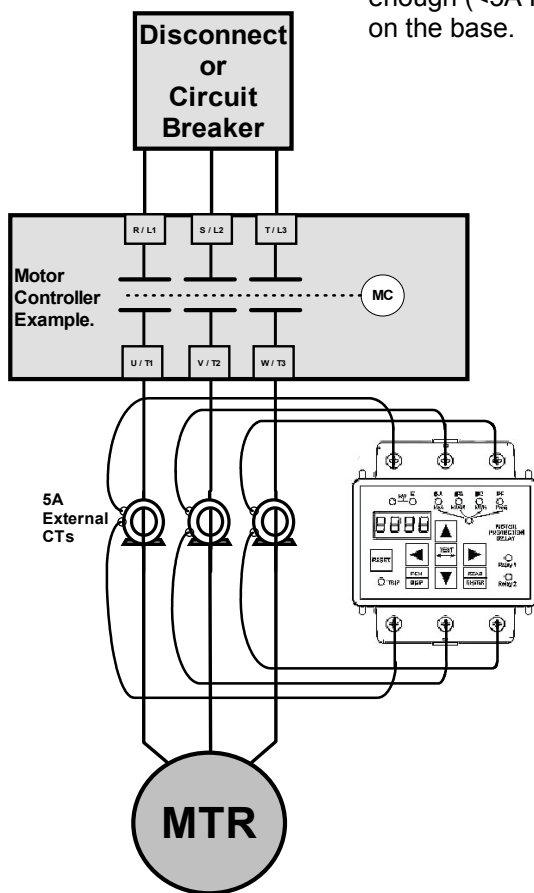

Figure 4.1.1.a:
RX-5-E Basic Connections
for Large Motors

4.1.1.a Large Motor Connections. The RX-5 is also used for large motors where external CTs are necessary to step the motor current down to 5A. Simply pass the motor leads through the external CT windows, then connect the CT secondary conductors to the RX-5 terminal adaptor (or pass them through the internal CT windows). You must also reprogram Function F073 for the external CT ratio in order to make the RX aware of the higher motor currents

4.1.1.b Motor Power Connections (continued)

On the RX-40-P and RX-75-P, the user can just pass the motor lead connections through the internal CTs of the RX Series relay base without making connection directly to the relay. This can also be done with the RX-5-P by removing the connection adaptor.

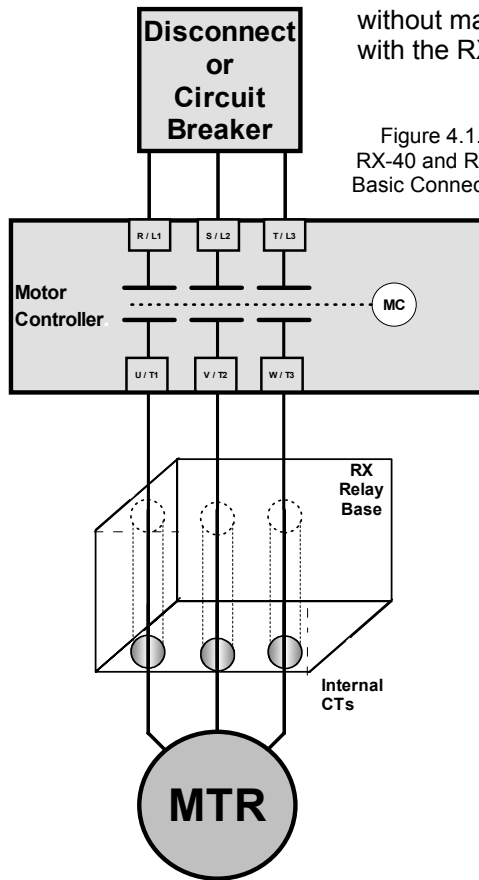

Figure 4.1.1:
RX-40 and RX-75
Basic Connections

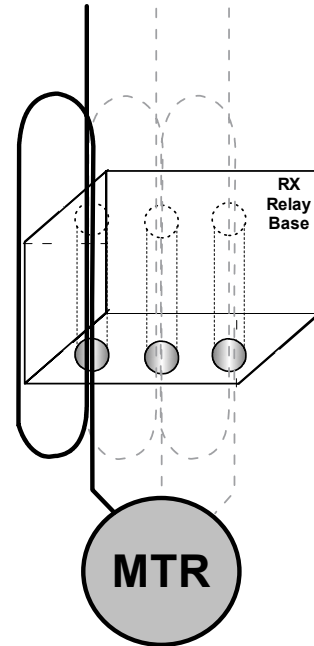

Figure 4.1.1.a
Example of 2 primary turns through internal CT
(only Phase A shown for clarity)

4.1.2 Using Primary Turns to Increase Range.

The RX relay can be used to read motor currents lower than the standard rating of the unit by increasing the current read by the CTs through the use of “Primary Turns”. Each “turn” refers to the fact that the power conductor is passing through the CT core. 2 passes through the core is referred to as 2 Primary Turns, also meaning that the current read by the CT is increased 2 times (2x). 4 Primary Turns would then mean that the motor conductors pass through the CTs 4 times and the current read is 4x the CT current. Another way to look at it is that the relay range has been divided by the number of turns. For example, if the motor FLA is between 5A (upper limit of the RX-5) and 20A (lower limit of the RX-40), use the RX-40 and pass the current through the built-in CT windows for more turns. For loads from 5 -10A, make a loop to pass the motor leads through 4 times (4 “turns”). The max. amp rating is now $40 \div 4$ or 10A, so the range is 5 – 10A. For loads 10 – 20A, use 2 Primary Turns through the windows for a rating of $40 \div 2$ or 20A, so a new range of 10-20A. This doubles or quadruples the range of the relay, **but must be coordinated by programming the correct number of turns into F074** (see section 5.6.12.a for additional information).

4.1.2 Using Primary Turns to Increase Range (continued)

In general when using external CTs, it is always best to choose a CT ratio that works out to have your motor FLA fall within the range of adjustment of the RX relay. Unfortunately this cannot always be accomplished with the available components. So **Primary Turns** can also be used with external CTs on the RX-5 to increase the range of the RX relay for motors who's FLA falls outside of its settings. For instance, if a motor has 240FLA, and you must use an external CT rated 500:5, the 5A CT current will represent a maximum of 500A, but the relay can only be turned down to 2.5A, so the lowest adjustment would be 250A, above the motor FLA. To achieve proper protection, pass the 5A CT current through the relay CT windows twice (2 turns). The 5A external CT current now represents 250A, so the range of adjustment becomes 120 – 250A, which properly covers the motor nameplate FLA.



Remember when doing this to always program the External CT ratio into Function F073, as well as the Primary Turns into F074. This allows your display and protection settings to accurately represent the actual motor power readings. See section 5.6.12.a for details on programming those functions.

4.1.3 Power Factor Correction Capacitors

Power factor correction capacitors can be connected to motors controlled by **RX Series** relays, however because the RX Series measures power factor for several functions, the PFC capacitors should be connected downstream of the relay.

4.1.4 Grounding

The **RX Series** relay is designed in a totally insulated case for use in a "floating ground" condition, there are no grounding provisions provided or necessary.

4.1.5 Testing

The **RX Series** can be tested by forcing the relay contacts. See Fn **F111** in section 5.6.18 for more details.

4.2 Control Connections

Control connections on the **RX Series** relay are divided into 2 groups. With the unit oriented vertically, TB1 is a 5 point DC terminal block (on the top), and TB2 is a 7 point AC terminal block (on the right side).. Following are descriptions of control connection points.

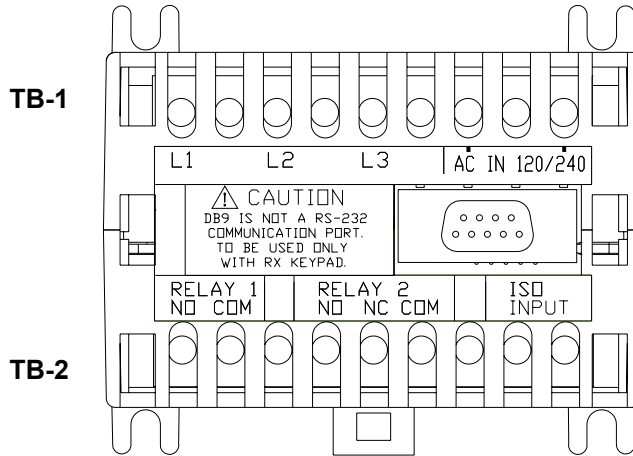

Figure 4.2: Control Terminal Blocks

4.2.1 AC Control Power Supply Connection

Separate AC Control Power supply is required to power the electronics of the **RX Series** relay. Control power can be anywhere from 85 to 265VAC, either 50 or 60 Hz, and must be connected to terminals marked “AC IN 120/240VAC” of TB-2. These terminals are the equivalent of A1 and A2 in IEC terminology, as shown in figure 4.2.1 below. This control voltage must be customer supplied.

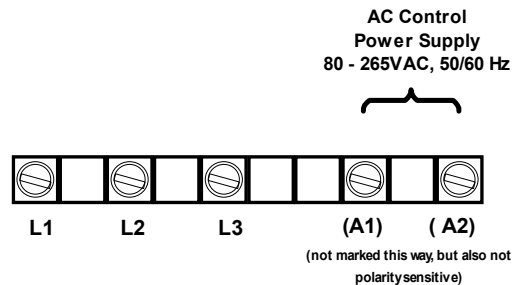

Figure 4.2.1
Control Power Supply Connection
TB-1

Control Power Requirements

The **RX Series** uses very little control power, less than 10 watts total when operating. The RX relay is internally fused at 125mA.

4.2.2 Control Connections

Output relays in TB2 have different power ratings. Relay 1 is designed for higher power operation, 10A 240VAC resistive or inductive and carries a 1/3HP rating at 120VAC (max. 10.0 LRA). Relay 2 is rated 5A 240VAC resistive, 1200VA maximum and is not rated for direct switching of motors. Both relays must be protected from currents in excess of their ratings, either with a fuse or with other suitable current protection devices.

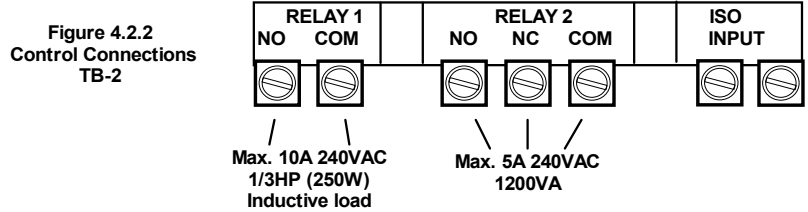

4.2.3 Two Wire Isolated Input / PLC Connection

An optional Isolated Input is provided that can be used with a dry contact, for example from a separate contact on a switch, relay or relay output of a PLC. This input can be programmed as either a Start / Run command for use in conjunction with the Process Timer and/or Time Clock Controller functions, or as a Remote Start when using serial communications control. It can also be programmed as an External Trip function. See F063 in section 5.6.11 for additional information.

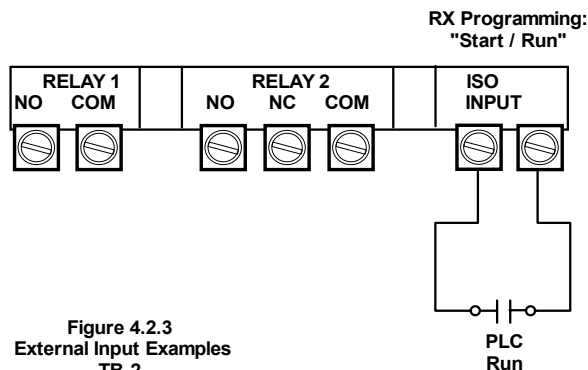
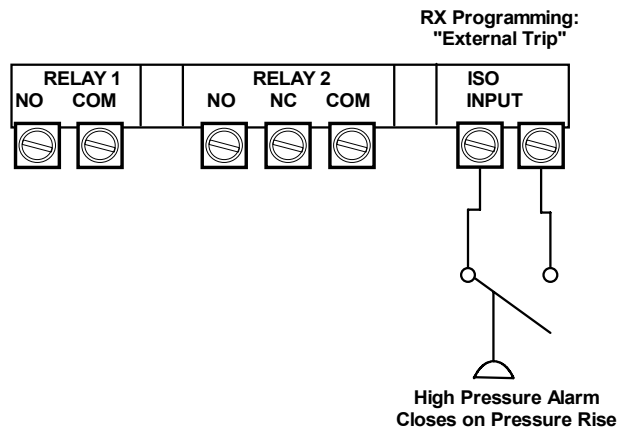

Figure 4.2.3
External Input Examples
TB-2

4.2.4 Output (Auxiliary) Relay Contacts

Two programmable Output Relays are on TB2. Relay #1 is a Form A (SPST) with a N.O. contact set up as a “Fail Safe” relay. See F109 in section 5.6.17 for instructions on converting this relay to normal (Direct Acting) operation.

Relay #2 is a Direct Acting Form C, (SPDT) with a Common, N.O. and N.C. contact.

All relays can be reprogrammed for a wide variety of functions. See Section 5.6.7 for additional relay programming details.

Typical Control Use

Using the factory default settings, Relay 1 (SPST) would be used as the Trip Relay, with the NO – Held Closed contact wired into the motor controller coil circuit, similar to an overload Relay NC contact (97, 98 designation in IEC terminology). The NO set of contacts in Relay 2, while connected in the same circuit via the Common terminal, can be used to provide fault status indication with a pilot light or PLC input as long as it is of the same voltage as the control circuit. If not, a completely separate control power circuit and source can be wired through Relay 2 because they are isolated from each other.

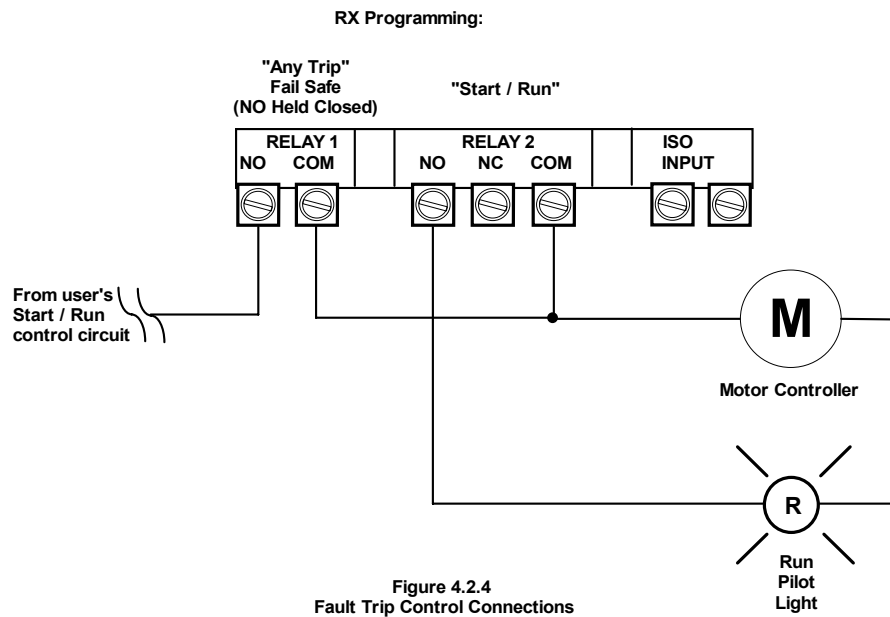

Complete Control

The RX Series has the capability of having complete control over the Motor Control Circuit via wiring and programming of both the Isolated Input and the 2 Output Relays, as shown in the following example. Many other configurations are possible with different programming.

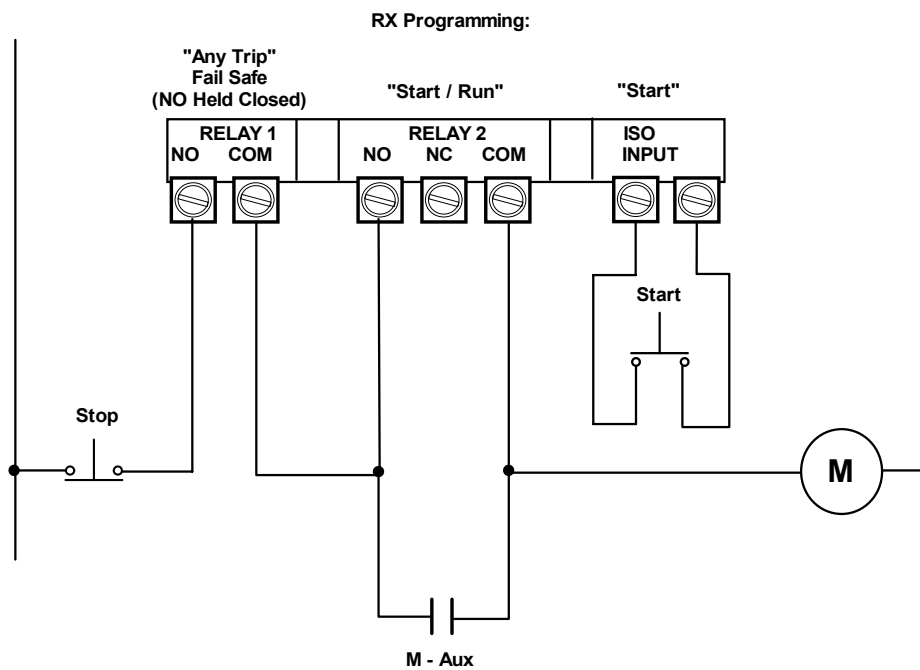

Figure 4.2.5
Complete Control Example
TB-2

Chapter 5 - Programming

**MOTOR FLA (F001)
must be programmed
for unit to operate!**

5.1 Introduction

It is best to operate the motor at its full load starting conditions to achieve the proper time, torque and ramp settings. Initial factory settings are set to accommodate general motor applications and provide basic motor protection. Advanced features must be enabled via programming. The only parameter that **MUST** be set by the user is motor FLA (F001).

5.2 Digital Interface

The **RX Series** Soft Relay includes an intuitive, digital keypad with eight LEDs, seven command keys, and an LED display with four alphanumeric digits.

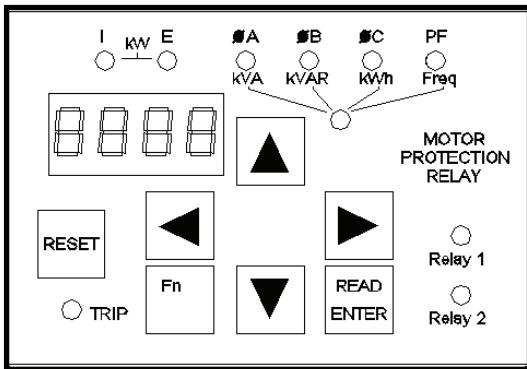

Figure 5.2: Operator Interface

| | | |
|----------------|------------------------|---|
| Keys | Reset | Clears the Trip indication and releases the Trip Relay. |
| | Fn | Enters or exits the Program Mode. |
| | Read/Enter | Used to Read a value of either a Function or its contents. After changes are made, pressing it again "Enters" the changes in to the relay EEPROM memory (stores). |
| | Up and Down Arrows | Navigates through the Status Display Mode, scrolls up and down through the Function List, increases or decreases the value of the active (flashing) digit and scrolls through the fault history. When entering values, holding the key down for more than 2 seconds will activate Auto-step, which increases it's rate the longer the key is held down. |
| LEDs | Right and Left Arrows | Each key press shifts the active (flashing) digit to the right or left by one position, allowing you to change higher values of functions without waiting to Auto-step though large numbers. |
| | Trip | Lights whenever any Trip function is active, stays lit as long as the relay is in Trip Mode (see below). |
| | Relay 1 and 2 | Lights when the respective relay is energized |
| | I and E | "I" LED indicates the value of the display is based on Current. "E" LED indicates the value in the display is based on Voltage. If both are lit simultaneously, the displayed value is kW (motor power) |
| | Phase A, B and C | Indicates that the displayed value is based on the phase(s) shown. If all 3 are On, this indicates the value shown is an Average of all 3 phases. |
| | PF | Indicates that the displayed value is Motor Power Factor |
| | (Lower) | Lights to indicate that the Phase LEDs described above are indicating the status is based on the descriptions shown below the LEDs instead of above. So the A, B, C and PF LEDs become kVA, kVAR, kWH and Frequency respectively. |
| | kVAR, kVAR, kWH, Freq. | 2 ND Tier indicating that the displayed value is one of these power conditions (instead of Phase Currents and Power Factor). |
| Display | 8888. | 4 digit 7 segment display with a decimal point on the right side indicating Phase A. |

Table 5.2: RX Series Display Features

5.3 Display Modes

There are three modes of display: the Status Display Mode, the Program Mode, and the Fault Mode.

5.3.1 Status Display Mode (Default Display)

The Status Display Mode displays 20 “screens” of information as shown in the chart below. This is the default mode when the RX Series relay is first powered on and also the point from where the Program Mode can be entered. Although all 20 screens can be scrolled through, the first screen (default screen) can be programmed in **F076**, see section 5.6.12.b for additional details.

| Action | Scroll Through Displays | Display Example | LED's Steady | LED's Blinking | Remarks |
|---------|--|---|----------------|----------------|--|
| Default | Current in Phase A | 0477 | I + ØA | | |
| △ key | Current in Phase B | 0480 | I + ØB | | |
| △ key | Current in Phase C | 0483 | I + ØC | | |
| △ key | Average Current | 0480 | I + ØA, ØB, ØC | | |
| △ key | Current Imbalance % | 0001 | I | ØA, ØB, ØC | |
| △ key | Voltage AB | 0230 if V<=9999 02.36 if V>9999 (indicating kV or 2360V). | E + ØA, ØB | | Decimal point is added to the center if Voltage exceeds 9999V, indicating the content value is kV |
| △ key | Voltage BC | 0228 | E + ØB, ØC | | |
| △ key | Voltage CA | 0233 | E + ØA, ØC | | |
| △ key | Average Voltage | 0230 | E + ØA, ØB, ØC | | |
| △ key | Voltage Imbalance % | 0002 | E | ØA, ØB, ØC | |
| △ key | Power Factor | └ 0.85 , or └ 1.03 | PF | | └: Inductive Load (lagging) └: Capacitive Load (leading) |
| △ key | Motor power (kW) | 1000, if (kW)<=9999 0001. if (kW)>9999 (indicating MW). | I + E | | Decimal point is added to the right if the displayed value is greater than 9999, which indicates the content value is MW (or MVA, MVAR, MWh as the case may be). |
| △ key | kVA | Similar to above, except kVA | ØA + Row2 | | |
| △ key | kVAR | Similar to above, except kVAR | ØB + Row2 | | |
| △ key | Energy use in kWh | Similar to above, except kWh | ØC + Row2 | | |
| △ key | Frequency | 060.0 | PF + Row2 | | Left digit is always 0 |
| △ key | Ground Current | G002 | | | |
| △ key | Process Timer Remaining Time | 0014 (minutes) | | Display | Blinks when process time is counting down. |
| △ key | Time Clock Controller Time (24hr format) | 01.20 | | Decimal Point | Blinks after start input is closed. |
| △ key | Remaining Motor Thermal Capacity | H100 | | | “H” can be thought of as motor “Heat” capacity |
| △ key | Scrolls back to beginning | | | | |

5.4 Program Mode

The relay must be Stop Mode in order to enter the Program Mode.

Use the Program Mode to view or change Function (Fn) settings. To enter the Program Mode, press the **[Fn]** key once from the Status Screen described in 5.3.1 above. The first time you enter the Program Mode after power has been cycled to the relay, the initial function **[F001]** should display with the selected digit flashing. If the **RX Series** relay has been programmed and power to the unit has not been cycled, the readout will display the last function viewed or changed. To change to a different function, use the arrow keys.

5.4.1 Viewing Function Programming and Values

The programming of each individual Function can be viewed without making changes (values can also be viewed in the Run Mode, however no changes can be made). Each Function is signified by the letter “F” in beginning of the data, the 4 digit value of the function follows after hitting the **[READ/ENTER]** key

- **[F001]** The “F” indicates the programmable Function.
- **[0000]** This is the present setting of the applicable function. This display may include decimals between digits depending on the function setting’s range and incremental steps.

Example: Figure 5.4.1

**Viewing a Function’s Set Value:
Motor FLA Setting**

[0000] Indicates that Phase A is drawing no current (unit is in Off mode).

Press the Fn key

[F001] Indicates that this is Function 001 (Motor FLA).

**Press Read / Enter key
to view the F001’s value**

[0360] Indicates that the programmed motor FLA is 360 Amps.

**Press the Fn key
to return to the function**

[F001] Indicates that you have returned to the Function Select screen.

**Press the Fn key again
to return to the Status Display Mode**

[0000] Default screen.

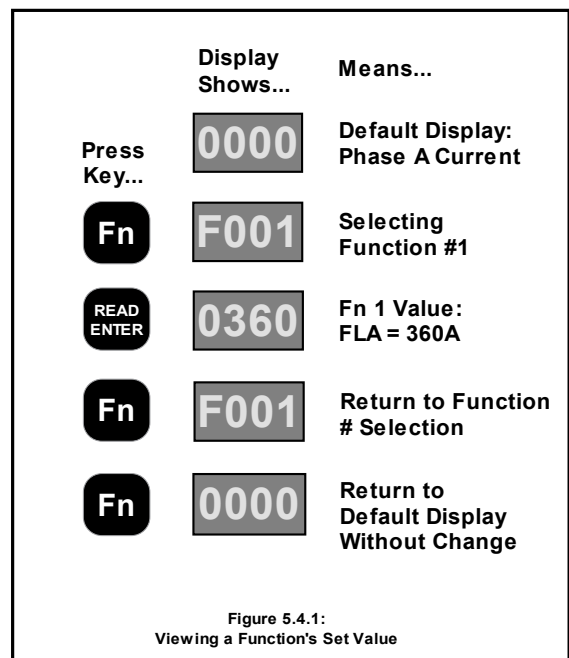

▪ **Note:**

If password protection has been enabled, operator will need to obtain password access before function settings can be changed. See Section 5.6.12 and Appendix A.

5.4.2 Enabling Password Protection / Parameter Lock

The **RX Series** relay is shipped with the Level 1 password protection disabled (F070 = 0). If it becomes necessary to prevent these parameters from being changed inadvertently, set the password in function F070. See section 5.6.12 and Appendix A for details. If the display reads [Loc] when the [READ/ENTER] key is pressed, the parameter lock is enabled.

Because they involve safety issues, functions F071 through F108 are password protected by F072 and this is shipped with the password ENABLED. Contact the factory for access to these functions.

5.4.3 Changing a Function's Set Value

From the instructions above, after hitting the [READ/ENTER] key the display will show the value of that function with one digit flashing (usually the rightmost digit). Flashing indicates this is the digit to be altered (similar to cursor position). Use the UP arrow key to increment the value of the flashing digit. Use the DOWN arrow key to decrement the value of the flashing digit. Use the LEFT or RIGHT arrow to select the next digit to be altered. Values can only be changed within the Adjustment Range of the function parameter.

Example 1: Figure 5.4.3

Viewing a Function's Set Value

- [0000] Indicates Phase A is drawing no current (unit is in Off mode).
Press the [Fn] key
- [F001] Indicates this is Function 001 (Motor FLA).
Press [READ/ENTER] key to view the F001 value
- [0048] Indicates the programmed motor FLA is 48 Amps. The farthest left digit (8) is flashing, indicating that this is the digit that you will alter (cursor position).
Press the UP Arrow key to increase this digit value
- [0049] Indicates you have increased the left digit to a value of 9.
Press the LEFT Arrow key to shift left to the next digit
- [0049] The second digit from the left is now flashing, indicating a new cursor position.
Press the UP Arrow key to increase this digit value
- [0059] Indicates you have increased the 2nd to left digit to a value of 5 (10's place).
Press [READ/ENTER] key to store the new value
- [End] The word "End" will flash briefly to indicate that the new value has been entered and accepted. After flashing once, the display will revert to showing the Function number.

Example 1: Setting the Motor FLA

Change FLA from 48 to 59A

| | Display Shows... | Means... |
|--------------|------------------|----------------------------------|
| Press Key... | | Phase A Current |
| | | Function #1 Selected |
| | | Previous Setting of Function #1 |
| | | New Value of First Digit |
| | | Cursor (flashing) Position Shift |
| | | New Value of Second Digit |
| | | Value Accepted (flashes once) |
| | | Return to Function # Display |

Figure 5.4.3: Changing a Function Value

▪ **5.4.3.a Changing a Value by Increments**

Although it may be easier to shift the cursor position, it is also possible to increase or decrease values by pressing the UP or DOWN arrow keys successively. This will change the Function value by the incremental amount associated with that Function. The Function List shows increment values for each Function.

Example 2: Figure 5.4.3.a

Changing a Function’s Value by Increments

[0000] Indicates that Phase A is drawing no current (unit is in Off mode).

Press the [Fn] key

[F001] Indicates that this is Function 001 (Motor FLA). The farthest left digit (1) is flashing, indicating this is the digit that you will alter (cursor position)

Press the UP Arrow key twice to increase this digit value to 3

[F003] Indicates that this is Function 003 (OL Class During Start).

Press [READ/ENTER] key to view the F003 value

[0010] Indicates that the programmed OL is Class 10 during the Start Mode. Cursor flash in on leftmost digit.

Press the UP Arrow key to increase this digit value

[0015] Indicates that you have increased the Function value by the increment assigned to it, a value of 5 in this case.

Press the UP Arrow key again to increase this digit value

[0020] Indicates that you have again increased the Function value by the increment assigned to it.

Press [READ/ENTER] key to store the new value

[End] The word “End” will flash briefly to indicate that the new value has been entered and accepted. After flashing once, the display will revert to showing the Function number.

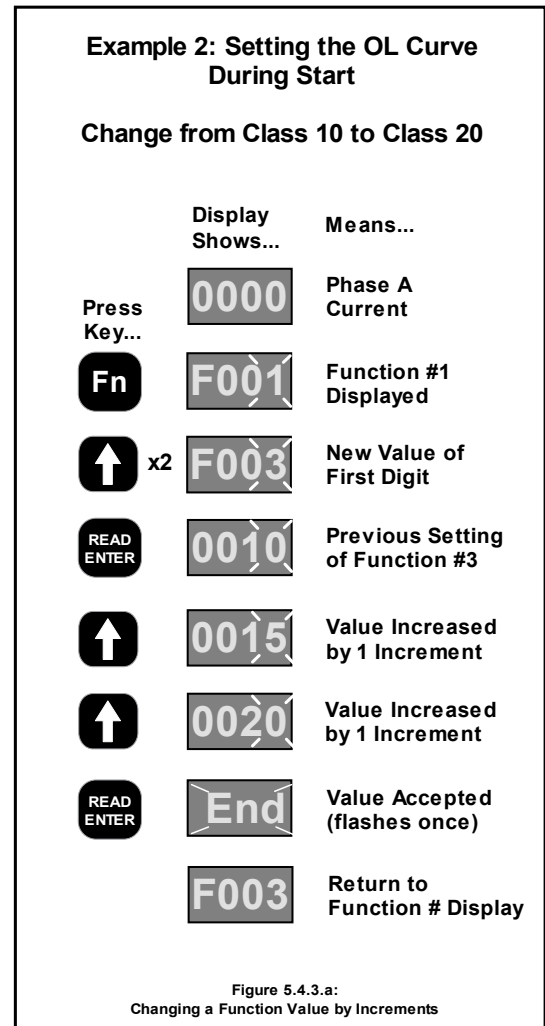

5.4.4 Storing the Altered Value of a Function

Once the desired value is displayed, press the **[READ/ENTER]** key. This stores the value in memory. The readout momentarily displays **[End]** and then returns to the function code.



Caution!

If the Fn key is pressed or power is lost *before* the **[READ/ENTER]** key is pressed, the *RX Series* Relay will not store the selected value in memory.

5.4.5 Fault Mode

The Fault Mode Display provides information to the operator when a fault occurs and allows the operator to review fault history. Refer to Section 7 for details. Fault codes are three-digits in length and are displayed in alpha characters. The first and second characters (reading left to right) are the initials for the applicable English-language fault name. The third or right-most character can be either A, c, or d to denote when the fault occurred. “A” denotes Acceleration. “c” denotes Constant speed. “d” denotes Decel.

Example: Figure 5.4.5

Viewing a Fault and History

[PLA.] Indicates that there was a Phase Loss during Acceleration. The Decimal point on the right signifies that this is the current fault.

Press the UP Arrow key

[iBc] Displays the previous fault, a Phase Imbalance during Constant Speed (running)

Press the UP Arrow key

[oLc] Displays the oldest fault, an Over Load trip during Constant speed (running).

Press [RESET] key

[rSt] Flashes once to indicate a successful Reset of the current fault. If it cannot be reset, the display will read [inH] for Inhibited.

[0000.] Returns to Default Display, indicating that the unit is ready to re-start.

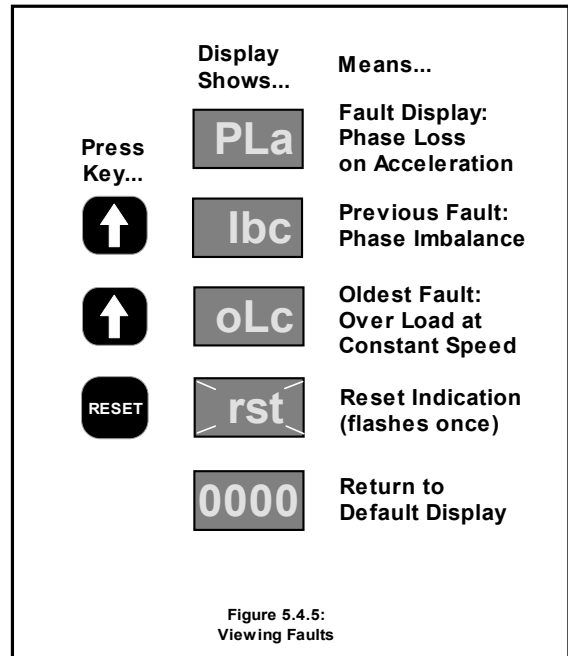

This Fault History can only be accessed during a fault condition. While the active fault number is being displayed, use the Up and Down Arrow keys to scroll through the Fault History. An additional Fault History complete with Time and Date stamps is also available for viewing at any time in F085 through F093.

▪ **5.4.5.a Resetting Faults**

Once a fault condition has been corrected, pressing the Reset key will return the readout to the Status Display mode. To reset faults, press the [RESET] key on the keypad. Alternatively, most faults will reset upon removal and return of control power. Over Load trips will NOT be reset in this way unless sufficient time has passed for the Thermal Register to regain sufficient capacity for a successful restart (see section 3.1).

▪ **5.4.5.b Remote Reset**

Because most trips can be reset by removing control power, remote reset can be accomplished this way. A NC remote contact (or push-button) can be placed in the control power supply to A1 or A2 and opened to facilitate a trip reset. See figure 5.4.5.b for a suggested connection.

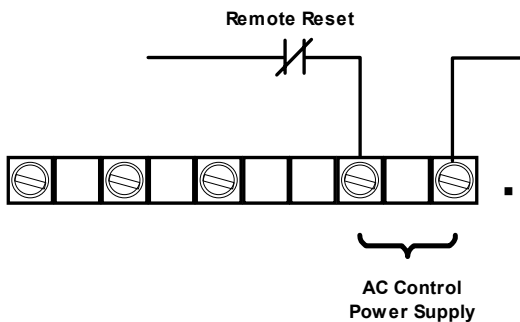

Figure 5.4.5.b
Remote Reset Connection
TB-2

- **5.4.5.c Automatic Reset**
The **RX Series** relay provides for automatic reset on certain non-critical faults and Over Load. For non-critical fault resets, see section 5.6.13 for program details of F077 and F078. For automatic Over Load reset, see section 3.1 and 5.6.1 for programming details.

- **5.4.5.d Lockout Functions**
Lockout functions such as Minimum Time Between Starts and Starts per Hour are not true fault conditions. They are based on the internal Real Time Clock (RTC). When control power is removed, the RTC value is quickly stored. Upon return of power, the timer values are updated from the RTC for elapsed time. If the Lockout Time has not expired, the **RX Series** cannot be started. To reset the Lockout Times for emergency restart, see section 5.6.12, under F071.

- **5.4.5.e Changing to Default Screen During Fault**
In some cases it may be necessary to alter programmed parameters in order to test or make changes to clear a fault (such as Phase Loss) or to view the more detailed fault history in F087 – F095. To accomplish this, you must get to the Status Screen so the Fn button becomes active. When in a Fault Screen, pressing the Right or Left Arrow buttons will take you to the Status Screen. From there, you can hit the **[Fn]** key to enter the Programming Mode and move to different functions.

5.5 The RX Function List
Motor and Line Data Functions

| Fn # | Group | Function Description | Adjustment / Display Range | Setting Increments | Factory Setting | Section |
|------|--------------------------|--|--|--------------------|-----------------|---------------|
| F001 | Motor and Overload Info. | Motor Nameplate FLA FLA must be programmed for relay to function. | 1 – 2000A, adjustable between 50-100% of Max Amp Rating. Upper limit of range automatically adjusts downward as Service factor is increased. | 1 amp | 0 | 5.6.1 and 3.2 |
| F002 | | Motor Nameplate Service Factor | 1.00 - 1.30 SF | 0.05 | 1.0 SF | |
| F003 | | Overload Class During Start | NEMA / UL Class 5 - 20 | 5 | Class 10 | |
| F004 | | Overload Class During Run | NEMA / UL Class 5 - 30 | 5 | Class 10 | |
| F005 | | Overload Reset | 0 = Manual 1 = Auto 2 = Disabled Overload | 1 | 0 (Manual) | |
| F006 | | Voltage Input (nominal Line) | 200 – 600 volt | 1 | 480 | |
| F007 | | kV Voltage Input (nominal line, Medium Voltage) | .60 – 15kV | .01 | 4.16 | |
| F008 | | Line Frequency | 50 or 60 Hz | - | 60 | |
| F009 | | Acceleration Time | 0-300 seconds [0=Disabled] | 1 | 30 | |

Table 5.5.1: Motor and Overload Function Group

Current and Ground Fault Settings

| Fn # | Group | Function Description | Adjustment / Display Range | Setting Increments | Factory Setting | Section |
|------|-------------------------------------|---------------------------------|-------------------------------------|--------------------|-----------------|---------|
| F010 | Current and Ground Fault Protection | Current Imbalance Trip % | 0, 1 - 30% of FLA [0=Disabled] | 1(%) | 0 | 5.6.2 |
| F011 | | Current Imbalance Trip Delay | 1 - 20 seconds | 1(Second) | 2 | |
| F012 | | Over Current Trip % | 0, 50 – 300% of FLA [0=Disabled] | 1(%) | 0 | |
| F013 | | Over Current Trip Delay | 1 - 20 seconds | 1 | 1 | |
| F014 | | Under Current % | 0, 10 – 90% of FLA [0=Disabled] | 1(%) | 0 | |
| F015 | | Under Current Trip Delay | 1 - 60 seconds | 1 | 2 | |
| F016 | | Stall Detection Trip Level | 0, 100 – 600% of FLA [0=Disabled] | 5(%) | 0 | |
| F017 | | Stall Detection Trip Delay | 1 - 10 seconds | 1 | 2 | |
| F018 | | Peak Current Trip % | 0, 800 – 1400% [0=Disabled] | 10(%) | 1000 (%) | |
| F019 | | Peak Current Trip Delay | 0, .01 - .5 seconds | .01 | .05 | |
| F020 | | Ground Fault Current Trip Value | 0, 5 – 90% of CT Value [0=Disabled] | 1(%) | 0 | |
| F021 | | Ground Fault Current Trip Delay | 1 – 60 seconds | 1 | 2 | |

Table 5.5.2: Current and Voltage Protection Function Group

Voltage Protection Settings

| Fn # | Group | Function Description | Adjustment / Display Range | Setting Increments | Factory Setting | Section |
|------|--------------------|-------------------------------|----------------------------|--------------------|-----------------|---------|
| F022 | Voltage Protection | Voltage Imbalance Trip % | 0, 1 – 30% [0=Disabled] | 1(%) | 0 | 5.6.3 |
| F023 | | Voltage Imbalance Trip Delay | 1 – 20 seconds | 1 | 10 | |
| F024 | | Over Voltage Trip % | 0, 1 – 10% [0=Disabled] | 1(%) | 0 | |
| F025 | | Over Voltage Trip Delay | 1 – 20 seconds | 1 | 10 | |
| F026 | | Under Voltage Trip on Start % | 0, 1 – 20% [0=Disabled] | 1(%) | 0 | |
| F027 | | UV Trip on Start Delay | 1 – 180 seconds | 1 | 10 | |
| F028 | | Under Voltage Trip on Run % | 0, 1 – 20% [0=Disabled] | 1(%) | 0 | |
| F029 | | UV Trip Delay during Run | 1 – 20 seconds | 1 | 2 | |

Table 5.5.3: Voltage Protection Function Group

Phase and Frequency Protection Settings

| Fn # | Group | Function Description | Adjustment / Display Range | Setting Increments | Factory Setting | Section |
|------|--------------------------------|----------------------------|--|--------------------|-----------------|---------|
| F030 | Phase and Frequency Protection | Phase Rotation Trip | 0, 1 or 2 0=Disabled, 1=ABC, 2=ACB] | 1 | 1 | 5.6.4 |
| F031 | | Phase Rotation Trip Delay | 1 – 20 seconds | 1 | 2 | |
| F032 | | Phase Loss Trip and Delay | 0, 1-20 Seconds [0= Disabled] | 1 | 1 | |
| F033 | | Over Frequency Trip Limit | 0, 1 – 10Hz [0=Disabled] | 1 | 0 | |
| F034 | | Over Frequency Trip Delay | 1 – 20 seconds | 1 | 2 | |
| F035 | | Under Frequency Trip Limit | 0, 1 – 10Hz [0=Disabled] | 1 | 0 | |
| F036 | | Under Frequency Trip Delay | 1 – 20 seconds | 1 | 2 | |

Table 5.5.4: Phase and Frequency Protection Function Group

Motor Power Protection Settings

| Fn # | Group | Function Description | Adjustment / Display Range | Setting Increments | Factory Setting | Section |
|------|------------------|--------------------------------|--|--------------------|-----------------|---------|
| F037 | Power Protection | Motor KW Trip | 0-2 0 = Disabled 1 = Over KW Trip 2 = Under KW Trip | 1 | 0 | 5.6.5 |
| F038 | | Motor KW Trip Point | 20 – 100% of full load KW | 1% | 50(%) | |
| F039 | | Motor KW Trip Delay Time | 1 – 999 minutes | 1 | 1 | |
| F040 | | Power Factor Trip Range | 0, 1 – 3 [0=Disabled, 1=l原因, 2=lead, 3= lead/lag] | 1 | 0 | |
| F041 | | Power Factor Trip Point | .01 – 1 | .01 | .50 | |
| F042 | | Power Factor Trip Delay Time | 1 – 20 seconds | 1 | 2 | |
| F043 | | Power Factor Current Direction | 0 - 1, [0=Normal, 1= Reversed] | 1 | 0 | |

Table 5.5.5: Power Protection Function Group

Lockout / Inhibit Settings

| Fn # | Group | Function Description | Adjustment / Display Range | Setting Increments | Factory Setting | Section |
|------|------------------------|--------------------------------------|---------------------------------|--------------------|-----------------|---------|
| F044 | Lockouts, and Inhibits | Coast Down (Back Spin) Lockout Timer | 0 = Disabled, or 1 - 60 minutes | 1 minute | 0 Disabled | 5.6.6 |
| F045 | | Maximum Starts per Hour | 0 = Disabled, or 1 – 10 starts | 1 | 0 Disabled | |
| F046 | | Minimum Time Between Starts Inhibit | 0 = Disabled, or 1 - 60 minutes | 1 minute | 0 Disabled | |

Table 5.5.6: Lockouts and Inhibits Group

Output Relay Settings

| Fn # | Group | Function Description | Adjustment / Display Range | Setting Increments | Factory Setting | Section | |
|------|---------------|---------------------------------------|-------------------------------|--|-----------------|------------------|--|
| F047 | Output Relays | Aux Relay 1 setting | Operation # 1 – 30: see below | 1 | 21 | 5.6.7 and 5.6.17 | |
| F048 | | Aux Relay 2 setting | Operation # 1 – 30: see below | 1 | 28 | | |
| | | Relay Programming Operation Options: | | 1 = Over Load During Start (OLA) | | | |
| | | | | 2 = Over Load Constant Speed (OLC) | | | |
| | | | | 3 = Any Overload Trip (OLA or OLC) | | | |
| | | | | 4 = Voltage Imbalance (EI) | | | |
| | | | | 5 = Over Voltage (OE) | | | |
| | | | | 6 = Under Voltage During Start (UEA) | | | |
| | | | | 7 = Under Voltage Constant Speed (UEC) | | | |
| | | | | 8 = Phase Rotation (Rt) | | | |
| | | | | 9 = Over Frequency (OF) | | | |
| | | | | 10 = Under Frequency (UF) | | | |
| | | | | 11 = Current Imbalance (CI) | | | |
| | | | | 12 = Over Current (OC) | | | |
| | | | | 13 = Stall Detection (Sd) | | | |
| | | | | 14 = Peak Current (PC) | | | |
| | | | | 15 = Under Current (UC) | | | |
| | | | | 16 = Ground Fault (GF) | | | |
| | | | | 17 = Power Factor (PF) | | | |
| | | | | 18 = KW Power Trip (Pr) | | | |
| | | | | 19 = Phase Loss (PL) | | | |
| | | | | 20 = External Trip (Et) | | | |
| | | | | 21 = Any Trip | | | |
| | | | | 22 = Coast Down Time (Cdt) Inhibit | | | |
| | | | | 23 = Starts Per Hour (SPH) Inhibit | | | |
| | | | | 24 = Time Between Starts (tbS) Inhibit | | | |
| | | | | 25 = Any Inhibit | | | |
| | | | | 26 = Any Trip or Inhibit | | | |
| | | | | 27 = Run Timer Engaged (F050) | | | |
| | | | | 28 = Start Command (1. External Digital Input AND Run Timer, if Run Timer engaged; 2. External Digital Input ONLY, if Run Timer disabled.) | | | |
| | | 29 = Motor Starting or Running Status | | | | | |
| | | 30 = Motor Running Status | | | | | |

Table 5.5.7: Output Relay Function Group

Status Settings

| Fn # | Group | Function Description | Adjustment / Display Range | Setting Increments | Factory Setting | Section |
|------|-------------|-------------------------|--|--------------------|-----------------|---------|
| F049 | Motor State | Motor Running Detection | 0, or 1-180 seconds 0 = Auto sensing. Current must go over 150% FLA first and then drop off to below FLA x Service Factor 1-180 sec. = Force to Run status after given delay time OR Auto sensing, whichever occurs first | 1 | 0 | 5.6.8 |

Table 5.5.8: Motor Status

Process Control Timer Settings

| Fn # | Group | Function Description | Adjustment / Display Range | Setting Increments | Factory Setting | Section |
|------|---|---|---|--------------------|-----------------|---------------------|
| F050 | Run Timer and Time Clock Controller Modes | Run Timer Selection | 0 = Disabled (No timer operation) 1 = Minimum (Batch) Run Timer 2 = Permissive Run Timer | 1 | 0 Disabled | 5.6.9 and Append. B |
| F051 | | Run Timer Time for use in F050 above | 1-9999 minutes after a Start Command or Start Event from TCC | 1 | 1 | |
| F052 | | 24hr Time Clock Controller (TCC) Start Event Mode. Chose "One Shot" or 1 to 7 "Start Events" from F053 – F059 Run time for this mode comes from F050 above. | Start Event Cycle (SEC) Settings. 1 = Loop SEC every day 2 = Loop SEC every 2 nd day 3 = Loop SEC every 3 rd day 4 = Loop SEC every 4 th day 5 = Loop SEC every 5 th day 6 = Loop SEC every 6 th day 7 = Loop SEC one day per week 8 = Single 24hr SEC (until programmed again) 0 = One Shot: Start Event comes from Start command only | 1 | 0 One Shot | |
| F053 | | Start Event #1 Start Time | 00:00-23:59 (hh:mm) or OFF | 1 | OFF | |
| F054 | | Start Event #2 Start Time | 00:00-23:59 (hh:mm) or OFF | 1 | OFF | |
| F055 | | Start Event #3 Start Time | 00:00-23:59 (hh:mm) or OFF | 1 | OFF | |
| F056 | | Start Event #4 Start Time | 00:00-23:59 (hh:mm) or OFF | 1 | OFF | |
| F057 | | Start Event #5 Start Time | 00:00-23:59 (hh:mm) or OFF | 1 | OFF | |
| F058 | | Start Event #6 Start Time | 00:00-23:59 (hh:mm) or OFF | 1 | OFF | |
| F059 | Start Event #7 Start Time | 00:00-23:59 (hh:mm) or OFF | 1 | OFF | | |

Table 5.5.9: Run Timer and Time Clock Controller Function Group

Communications Settings

| Fn # | Group | Function Description | Adjustment / Display Range | Setting Increments | Factory Setting | Section |
|------|----------------|----------------------|--|--------------------|-----------------|---------|
| F060 | Communications | Communications | Range: 0 – 4 0 = Disabled; 1 = Enabled (11 bit format) 2 = Enabled(10 bit format) 3 = Enabled (11bit) and Remote Start Control; 4 = Enabled (10bit) and Remote Start Control. | 1 | 0 | 5.6.10 |
| F061 | | Baud Rate | 4.8, 9.6 and 19.2 KB | 3 rates | 9.6 KB | |
| F062 | | Modbus Address | 1 - 247 | 1 | 1 | |

Table 5.5.10: Serial Communications Function Group

Input Contact Settings

| Fn # | Group | Function Description | Adjustment / Display Range | Setting Increments | Factory Setting | Section |
|------|------------------------|----------------------------|--|--------------------|-----------------|---------|
| F063 | External Input Control | External Dry Contact Input | Setting Range: 0-2 0 = Disabled; 1 = External Trip Input; 2 = Start Button Input Note: Start Button Input must be enabled while Run Timer or Remote Start Control is selected. | 1 | 0 | 5.6.11 |

Table 5.5.11: External Input Control

| Fn # | Group | Function Description | Adjustment / Display Range | Setting Increments | Factory Setting | Section |
|------|--|--|---|-----------------------------------|--------------------------------|----------------------|
| F064 | System Settings | Year | 2000 - 2047 | 1 year | 2000 | 5.6.12 |
| F065 | | Month | 1 - 12 | 1 Month | 1 | |
| F066 | | Day | 1 - 31 | 1 Day | 1 | |
| F067 | | Hour | 0 - 23 | 1 Hour | 0 | |
| F068 | | Minute | 0 - 59 | 1 Minute | 0 | |
| F069 | | Second | 0 - 59 | 1 Second | 0 | |
| F070 | | Parameter Lock Customer Level 1 Password | 0 – 999 0 = Disabled Any Other Numbers = Password Note: Level 1 = Fns 1 thru 71 + 109 and 111 | 1 | 0 (displays encrypted code) | 5.6.12 and Append. A |
| F071 | | System Clear / Reset | 0 = Disabled 1 = Clear THR and Lockout Timers 2 = Reset to Factory Defaults 3 = Clear kWh register | 1 | 0 | 5.6.12 |
| F072 | Parameter Lock Customer Level 2 Password | 2000 – 9999 0 = Disabled Any Other Numbers = Password Note: Level 2 = Fn 0071 thru 0108 | 1 | 2000 (displays encrypted code) | 5.6.12 and Append. A | |

Continued on next page...

System settings continued...

| | | | | | | |
|------|--------------------------|----------------------------|--|---|----|----------|
| F073 | System Settings cont. | CT Value | 5-2000 (:5). | 5 | 40 | 5.6.12.a |
| F074 | | Number of Turns through CT | 1 – 5 | 1 | 1 | |
| F075 | | PT Value | 1-200 (: 1) 1:1 = direct voltage input, 2-200:1 = kV Voltage Input | 1 | 1 | |
| F076 | | Default Status Display | 1 – 20 (see Table 5.6.12.b) | 1 | 2 | 5.6.12.b |

Table 5.5.12: System Settings Function Group

Auto Reset and Auto Restart Settings

| Fn # | Group | Function Description | Adjustment / Display Range | Setting Increments | Factory Setting | Section |
|------|------------------------|---|---|--------------------|-----------------------|--------------|
| F077 | Auto Reset and Restart | Auto Reset on Selected Faults | Fault Preferences 2 – 12 See Table 5.6.13: "Auto-Reset Selected Faults" | 1 | 4, Phase Loss only | 5.6.13. a |
| F078 | | Auto Reset Attempts | 0 = Disabled, or 1-10 attempts Notes: 1. Attempted reset interval is two minutes 2. Reset Attempt count will be refilled to setpoint value if RX has run twenty four hours without another trip. | 1 | 0 | |
| F079 | | Restart Delay Time (Sequential Start Delay) | 0 = Disabled, or 1-999 seconds after a Power Loss (Status can be read in F081) | 1 second | 0 Disabled | 5.6.13. b |

Table 5.5.13: System Settings Function Group

Firmware Record

| Fn # | Group | Function Description | Adjustment / Display Range | Setting Increments | Factory Setting | Section |
|------|-------|--------------------------|----------------------------|--------------------|-----------------|---------|
| F080 | | Firmware Revision Number | | | | 5.6.14 |

Table 5.5.14: Firmware Record

Timer and Counter Value Records

| Fn # | Group | Function Description | Adjustment / Display Range | Setting Increments | Factory Setting | Section |
|------|----------------------------------|---|----------------------------|--------------------|-----------------|---------|
| F081 | Inhibit Timer and Counter Values | Restart Delay Time Value Readout (for F079) | 0-999 Minutes | 1 | 0 | 5.6.15 |
| F082 | | Coast Down Timer Value for F044 | 1-3600 Seconds | 1 | 0 | |
| F083 | | Starts Per Hour Timer Value for F045 | 1-3600 Seconds | 1 | 0 | |
| F084 | | Starts Per Hour count For F045 | 1-10 Starts | 1 | 0 | |
| F085 | | Time Value Between Starts for F046 | 1-3600 Seconds | 1 | 0 | |
| F086 | | Thermal Capacity to Start for F005 | 0-100 % Thermal Capacity | 1 | 0 | |

Table 5.5.15: Inhibit Time and Counter Values Group

Fault History and Statistical Data

| Fn # | Group | Function Description | Adjustment / Display Range | Setting Increments | Factory Setting | Section |
|------|----------------------------|--|---|--------------------|-----------------|--------------|
| F087 | Fault History and Run Data | Fault History #1, Latest Fault | 0 = No fault history, or Fault # 1 - 57: see Fault code list | 1 | 0 | 5.6.16. a |
| F088 | | Time Stamp, Fault #1 Based on F078-80 | 00.00-23.59 (hh.mm) [hh = 00-23; mm = 00-59] | 00.01 | 00.00 | |
| F089 | | Date Stamp, Fault #1 Based on F076-77 | 01.01 – 12.31 (MM.DD) [MM = 01-12; DD = 01-31] | 00.01 | 01.01 | |
| F090 | | Fault History #2, Previous Fault | 0 = No fault history, or Fault # 1 - 57: see Fault code list | 1 | 0 | |
| F091 | | Time Stamp, Fault #2 | 00.00-23.59 (hh.mm) [hh = 00-23; mm = 00-59] | 00.01 | 00.00 | |
| F092 | | Date Stamp, Fault #2 | 01.01 – 12.31 (MM.DD) [MM = 01-12; DD = 01-31] | 00.01 | 01.01 | |
| F093 | | Fault History #3, Oldest Fault | 0 = No fault history, or Fault # 1 - 57: see Fault code list | 1 | 0 | |
| F094 | | Time Stamp, Fault #3 | 00.00-23.59 (hh.mm) [hh = 00-23; mm = 00-59] | 00.01 | 00.00 | 5.6.16. b |
| F095 | | Date Stamp, Fault #3 | 01.01 – 12.31 (MM.DD) [MM = 01-12; DD = 01-31] | 00.01 | 01.01 | |
| F096 | | Run Time, Hours | 000.0 – 999.9 hours | 0.1 hours | 0 | |
| F097 | | Run Time, 1000 Hour Overflow | 0000 – 9999 thousand hours | 1 k-hour | 0 | |
| F098 | | Run Cycle Counter | 0000 – 9999 times | 1 times | 0 | |
| F099 | | Run Cycle Counter 10K overflow | 0000 – 9999 10 thousand times | 10k times | 0 | |

Table 5.5.16: Fault History and Run Data Group

Fail Safe and Test Functions

| Fn # | Group | Function Description | Adjustment / Display Range | Setting Increments | Factory Setting | Section |
|----------|------------------------------|---|--|--------------------|---------------------|---------|
| F100-108 | Fail Safe and Test Functions | Reserved for Factory Use | No adjustment or valid display | | | |
| F109 | | Fail Safe Operation for Aux. Relay 1 | 0 – 2 0 = Relay operates in Normal Mode (Direct Acting) 1 = Relay operates in Fail Safe mode (NO Held Closed, Open on Trip) | 1 | 1 (Fail Safe) | 5.6.17 |
| F110 | | Keypad Firmware Version | Read Only | | | |
| F111 | | Relay Test | 0 = Disabled, or 1 = Test (force) Relay 1 2 = Test (force) Relay 2 Note: Relay stays Forced until the Reset Button is pressed or this function is reset to 0. | 1 | 0 Disabled | 5.6.18 |

Table 5.5.17: Test Function Group



Note: Relay testing may result in unwanted operation. Ensure that control circuits are disabled prior to testing the relay functions.

5.6 Function Descriptions

Your **RX Series** relay is set at the factory with typical default settings that perform well in most applications. Following are detailed descriptions of each Function and the factory default settings.

5.6.1 Motor and Overload Function Descriptions

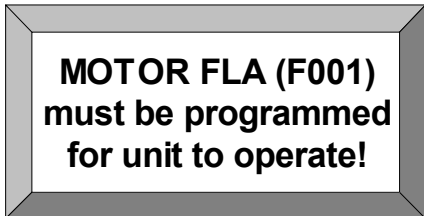

F001= Motor FLA

Factory Setting = 0

Range = 1 – 2000A, but limited by CT ratio (note 2).

Set the value of this function to the motor nameplate Full Load Amps (FLA) (see note 1). Adjustments for service factor are not necessary when programming this function. If the motor nameplate FLA is not available, use typical values as shown in NEC, NEMA standard MG-1 or other reputable third party source (motor manufacturer, etc.).



▪ **Notes:**

1. Use the actual motor nameplate FLA values in this function, even if using a CT for current sensing. Calculations are done internally to determine measured current based on the CT ratio programmed into F073. It will be necessary to program F073 first in that case.

2. The range of adjustment for the Motor Nameplate FLA will vary first in accordance with the **Adjusted CT Ratio** (the CT ratio in F073 and the number of Primary Turns in F074) and secondly in accordance with the Service Factor as programmed into F002. At the default setting of 1.0SF, the full range of adjustment up to the maximum current according to the Adjusted CT Ratio value is possible. As the Service Factor in F002 is increased, the FLA range will drop by an equal percentage. For example if the CT ratio in F073 is 50:5 (no extra turns in F074), the maximum setting is 50A. If F002 = 1.15 (1.15 Service Factor), the max amp rating becomes 50 – 15% (50 x .85) So the maximum FLA programmable into F001 will be limited to 42.5A.

F002 = Service Factor

Factory Setting = 1.0 S.F.

Range = 1.00 - 1.30

Set value according to the Service Factor (SF) data provided on the motor's nameplate. This value affects several protection features so it must be accurate. Setting the SF too high may result in motor damage in an overload condition. Setting SF too low may cause nuisance trips however, a 1.0 SF setting is safest if SF is unknown.



▪ **Note:**

IEC (metric) designed motors do not use Service Factors and as such are always 1.0.

F003 = Overload Class During Start**Factory Setting = 10 (Class 10)****Range = NEMA / UL Class 5 - 30**

Set value to the motor protection overload class required for the application. It is recommended that you try the factory setting first. (If possible, keep values for F003 and F004 the same.) Increase F003 above F004 only if nuisance tripping occurs during start. See Section 3.2 for details on trip curves.

F004 = Overload Class During Run**Factory Setting = 10 (Class 10)****Range = 5 - 30 NEMA / UL Class**

Set value according to the instructions provided by your motor / equipment manufacturer. This trip curve will not be enabled until the motor has reached full speed (as determined by settings of F049).

F005 = Overload Reset**Factory Setting = 0 (Manual)****Range = 0 – 2**

Set value to determine relay behavior after an overload condition has cleared.

When set to 0 = Manual, the operator must press the **[RESET]** key before restarting the motor. Once the motor windings have cooled sufficiently AND the **[RESET]** key is pressed, the unit will accept a restart command.

When set to 1 = Automatic mode, and once sufficient time has elapsed allowing motor windings to cool, the motor will be restarted upon a start command. If 2 wire control is used, the unit will restart immediately.

When set to 2 = Disabled Overload, the **RX Series** will *not* trip on Motor Thermal Overload. This is provided for applications where either an external Overload Relay or Motor Protection Relay is used.



- **WARNING:**
Setting F005 = 1 (Automatic) may present significant operational risk.
When F005 = 2 (Disabled Overload), a separate external thermal overload protection device must be in the circuit.



- **Note:**
Because of the risk of fire or equipment damage, cycling control power will NOT reset an Overload Trip. If F005 = 2 (Automatic Reset), cycling control power will allow reset ONLY IF the Thermal Register has determined that the motor has regained sufficient thermal capacity to allow it to restart successfully.

F006 = Voltage Input (nominal line voltage)**Factory Setting = 480 (V)****Range = 200 – 600 (V)**

Set to the nominal line voltage when used in Low Voltage Systems. This value is used for both display and calculations of kW, PF etc. Low Voltage rating is determined by the setting of the PT Ratio in F075. When F075 is set to 1 (1:1), the RX will read the value in this function as the Low Voltage rating, and the Medium Voltage setting in F007 will be ignored.

F007 = kV Voltage Input (nominal line Medium Voltage)**Factory Setting = 4.16 (kV)****Range = 0.6 – 15.0 (kV)**

Set to the nominal line voltage when used in Medium Voltage Systems. This value is used for both display and calculations of kW, PF etc. Medium Voltage rating is determined by the setting of the PT Ratio in F075. When F075 is set to any value other than 1 (1:1), (i.e. 200:1 on a 2400V system) the RX will read the value in this function as the Medium Voltage rating based on that PT ratio, and the Low Voltage setting in F006 will be ignored.

F008 = Line Frequency**Factory Setting = 60 (Hz)****Range = 50 or 60 (Hz)**

Set to the nominal line frequency. This value is used for both display and in trip functions F033 and F035.

F009 = Acceleration Time**Factory Setting = 30 (sec.)****Range = 0 – 300 (sec.); 0 = Disabled**

Set to the maximum acceleration time that the motor is allowed before tripping, regardless of whether or not it satisfies the settings of F016 (if used). Acceleration detection is determined by the setting of F049 (Motor Run Detection). Can be used as an incomplete Sequence Detection on reduced voltage starters.

Notes:

1. If F016 (Stall Detection) is used and the threshold is set lower than the threshold of F049 and the trip delay of F017 is shorter than the setting of F009, the lower settings takes precedence.
2. If F049 is set to a time value other than 0 to accommodate an expected long acceleration time and that time value is longer than the setting of F009, the relay may trip on Accel Trip before the motor fully accelerates. Make sure these two functions are properly coordinated.

5.6.2 Current and Ground Fault Protection Features

F010 – F021 set extended protection features that may be used in the **RX Series** relay. Percentages shown are all based automatically upon the Motor FLA setting from F001 (except Ground Fault, F020). No additional calculations are necessary.



- **Note:**
All of these features are disabled at the factory and must be enabled via user programming as follows:

F010 = Current Imbalance Trip

Factory Setting = 0 (Disabled)

Range = 1 - 30% or 0 (Disabled)

Use to set the trip level for when current imbalance between any two phases exceeds this amount for the time specified with F011.

F011 = Current Imbalance Trip Delay

Factory Setting = 2 seconds

Range = 1 - 20 seconds

Provides a time delay to prevent nuisance trips from short-duration transients. Using default settings, if the difference in output current between two phases exceeds 10% of FLA for more than 2 seconds, the relay will trip.

F012 = Over Current Trip / Shear Pin Trip

Factory Setting = 0 (Disabled)

Range = 50 - 300% FLA, 0 (Disabled)

When a value other than 0 is entered for F012, the relay will trip when the output current of any phase exceeds the amount set and the time specified in F013. This is also referred to as a “Shear Pin Trip” and can be used to protect mechanical components from breaking due to jammed loads.

F013 = Over Current Trip Delay

Factory Setting = 1 second

Range = 1 - 20 seconds

Provides a time delay to prevent nuisance trips from short-duration transients. For example using default settings, if the output current of any phase exceeds F012 for more than 1 second, the relay will trip.

F014 = Under Current Trip

Factory Setting = 0 (Disabled)

Range = 10 - 90% FLA, or 0 (Disabled)

When a value other than 0 is entered for F044, the relay will trip when the output current of any phase drops below the amount set, and the time specified in F015. This fault condition is often referred to as a “Load Loss Trip” and can be used to detect a broken shaft, V belt or other mechanical drive system component. In pumping applications, this can be used as a “Loss of Prime” trip.

F015 = Under Current Trip Delay

Factory Setting = 2 seconds

Range = 1 - 60 seconds

Provides a time delay to prevent nuisance trips from short-duration transients. Using default setting, if the output current of any phase drops below F014 for more than 2 seconds, the relay will trip.

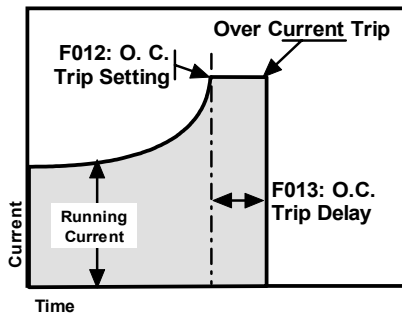

Figure 5.6.2.a:
Over Current Trip

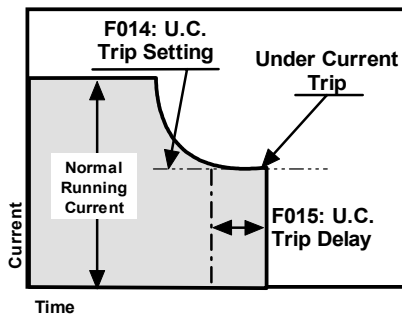

Figure 5.6.2.b:
Under Current Trip

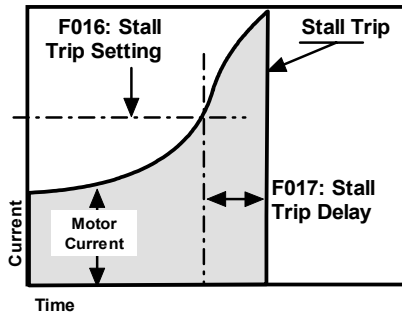

Figure 5.6.2.c:
Stall Trip

F016 = Stall Detection Trip Level

Factory Setting = 0 (Disabled)
Range = 100 - 600% FLA, 0 (Disabled)

When a value other than 0 is entered for F016, the relay will trip when the output current of any phase exceeds the amount set and the time specified in F017. This is similar to the Over Current Trip in F012 except the trip threshold levels can be set higher and should be used primarily to detect a locked rotor or incomplete acceleration.

F017 = Stall Trip Delay

Factory Setting = 2 second
Range = 1 - 10 seconds

Provides a time delay to prevent nuisance trips from short-duration transients. For example using default settings, if the output current of any phase exceeds F016 for more than 2 seconds, the relay will trip.

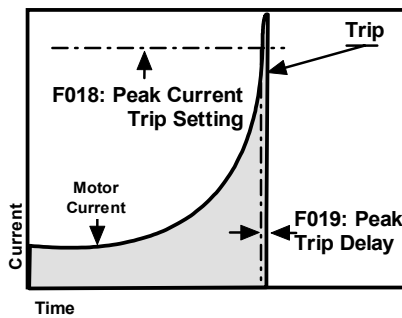

Figure 5.6.2.d:
Peak Current Trip

F018 = Peak Current Trip Level

Factory Setting = 0 (Disabled)
Range = 800 - 1400% FLA, 0 (Disabled)

When a value other than 0 is entered for F018, the relay will trip when the output current of any phase exceeds the amount set and the time specified in F019. This is similar to the Stall Trip in F017 except the trip threshold levels can be set extremely high and should be used primarily to detect a short circuit or other rapid increase in current that may damage equipment.

F019 = Peak Current Trip Delay

Factory Setting = 0.01 second
Range = 0.01 – 0.5 seconds, or 0 (instantaneous)

Provides a time delay to prevent nuisance trips from short-duration transients. For example using default settings, if the output current of any phase exceeds F018 for more than 0.01 seconds (10ms), the relay will trip.

- **5.6.2.a Ground Fault**

F020 – F021 provides Ground Fault protection for equipment only (a.k.a. Arcing Ground Fault) using the Residual Current method. Trip setting in F020 is based on the Adjusted CT ratio (see F001, Note 2). A delay time is available in F020 to help prevent nuisance trips. Ground current can always be viewed in the Status Display, shown with a “G” prefix (see section 5.3.1).

**WARNING!**

THIS IS NOT INTENDED TO BE USED AS "PERSONNEL PROTECTION" GROUND FAULT! This feature is only intended to provide a level of equipment protection against damaging ground currents. Ground faults are potentially dangerous conditions and must be corrected immediately for safety of operating personnel.

F020 = Ground Fault Trip

Factory Setting = 0 (Disabled)

Range = 5 - 90% of CT value, or 0 (Disabled)

When a value other than 0 is entered for F020, the relay will trip if current to ground exceeds this percentage of the unit CT value. The CT value is shown in F073 (see section 5.6.12). This value is different from the Unit Rating or FLA setting. To calculate actual ground current, multiply the Adjusted CT Ratio by the setting of F020.

Example:

18A relay used with 5A CTs on a motor with 220FLA, desired Ground Fault Trip level is 20A:

On this example, the CT value reading from F073 will be 500 (500:5) and the Primary Turns in F074 will be 2.

$500 \text{ (CT ratio)} \div 2 \text{ (Pri. Turns)} = \text{Adjusted CT Ratio of } 250:5$

$20 \text{ (desired current)} \div 250 \text{ (Adj. CT Ratio)} = 0.08 \text{ (8\%)}$

Set F020 to 8

F021 = Ground Fault Trip Delay

Factory Setting = 2 seconds

Range = 1 - 60 seconds

Provides a time delay to prevent nuisance trips from short-duration transients. Using default setting, if the Ground Fault current exceeds the level set in F020 for more than 2 seconds, the relay will trip.

**CAUTION:**

This method of Ground Fault sensing may not provide adequate equipment protection in resistance-grounded systems. We recommend providing external GF protection using a core balanced Zero Sequence CT for those types of applications. Consult factory for additional assistance.

5.6.3 Voltage Protection Features

F022 – F029 set extended protection features that may be used in the **RX Series** relay. Percentages shown are all based automatically upon the Line Voltage setting in either F006 (Low Voltage, 200-600V) or F007 (Medium Voltage, 600 – 15,000V). Low or Medium Voltage is determined by the setting of F075. No additional calculations are necessary.



- **Note:**
All of these features are disabled at the factory and must be enabled via user programming as follows:

F022 = Voltage Imbalance Trip

Factory Setting = 0 (Disabled)

Range = 1 - 30% or 0 (Disabled)

Use to set the trip level for when voltage imbalance between any two phases exceeds this amount for the time specified with F023.

F023 = Voltage Imbalance Trip Delay

Factory Setting = 10 seconds

Range = 1 - 20 seconds

Provides a time delay to prevent nuisance trips from short-duration transients. Using default settings, if the difference in voltage between two phases exceeds 10% of FLA for more than 10 seconds, the relay will trip.

F024 = Over Voltage Trip

Factory Setting = 0 (Disabled)

Range = 1 - 10% over nominal, 0 (Disabled)

When a value other than 0 is entered for F024, the relay will trip when the voltage of any phase exceeds the nominal voltage set in F006 or F007 by this percentage amount and for the time specified in F025.

F025 = Over Voltage Trip Delay

Factory Setting = 10 seconds

Range = 1 - 20 seconds

Provides a time delay to prevent nuisance trips from short-duration transients. For example using default settings, if the voltage of any phase exceeds the percentage set in F025 for more than 10 seconds, the relay will trip.

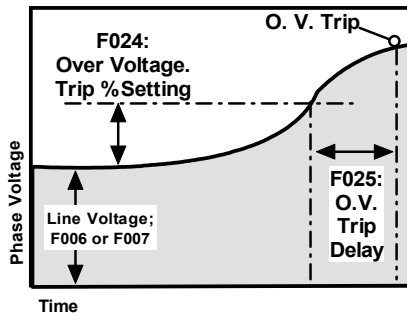

Figure 5.6.3.a:
Over Voltage Trip

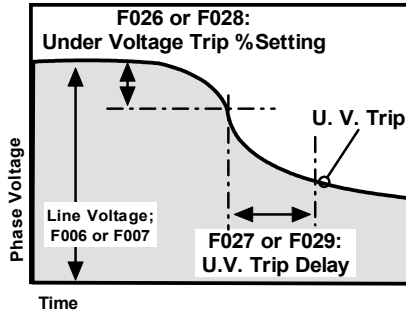

Figure 5.6.3.b:
Under Voltage Trip

F026 = Under Voltage Trip on Start
Factory Setting = 0 (Disabled)
Range = 1 - 20% under nominal, or 0 (Disabled)

When a value other than 0 is entered for F026, the relay will trip when the voltage of any phase drops below the nominal setting of F006 or F007 by this percentage amount and for the time specified in F027. This fault condition is only active during the Start mode, as determined by the settings of F049, to protect against excessive voltage drop on start-up. Once the relay has changed to Run mode, this function is replaced by F028.

F027 = Under Voltage on Start Trip Delay
Factory Setting = 10 seconds
Range = 1 - 180 seconds

Provides a time delay to prevent nuisance trips from short-duration transients. Using default setting, if the voltage of any phase drops by the percentage set in F026 for more than 10 seconds, the relay will trip.

F028 = Under Voltage Trip on Run
Factory Setting = 0 (Disabled)
Range = 1 - 20% under nominal, or 0 (Disabled)

When a value other than 0 is entered for F026, the relay will trip when the voltage of any phase drops below the nominal setting of F006 or F007 by this percentage amount and for the time specified in F029. This fault condition is only active after the relay enters the Run mode, as determined by the settings of F049, to protect against excessive voltage drop from the supply. While the relay is still in the Start mode, this function is ignored in favor of F026.

F029 = Under Voltage on Run Trip Delay
Factory Setting = 2 seconds
Range = 1 - 20 seconds

Provides a time delay to prevent nuisance trips from short-duration transients. Using default setting, if the voltage of any phase drops by the percentage set in F026 for more than 2 seconds, the relay will trip.



- **Note:**
Under Voltage and Over Voltage Trip settings may conflict with Voltage Imbalance Trip settings set in F022 and F023 because they are all based upon ANY phase voltage being out of range, not an average of all 3. If a voltage anomaly occurs that is set out of range of any feature, the one with the lowest settings and fastest trip time will take precedence.

5.6.4 Phase and Frequency Protection Features

F030 – F036 set extended protection features that may be used in the **RX Series** relay.



- **Note:**
SOME of these features are enabled at the factory, others are not and must be enabled via user programming as follows:

F030 = Phase Rotation Trip

Factory Setting = 1 (A-B-C)

Range = 1 (A-B-C); 2 (B-A-C) or 0 (Disabled)

The **RX Series** is set up to monitor an expected Phase Rotation and trip if it changes. Control of this is divided into two categories: On-Off and Expected Sequence. The default setting is On, with and Expected Sequence of A-B-C rotation (Setting 1).

The ability to turn this feature Off (setting 0) is useful in applications where the **RX Series** relay is going to be used downstream from an existing reversing contactor / starter, or to avoid conflicts with other protection devices.

On large motors where large multiple conductors are used, it may be easier to change the Expected Sequence in the **RX Series** relay rather than swap the conductors.



- **Note:**
There are several power utilities that, although they claim to provide A-B-C rotation, are actually using B-A-C rotation as defined by may rotation detection circuits such as that used by the RX Series relay (example, Pacific Gas and Electric in California). This only means that at initial startup, you may get a ROT trip indication even though you may believe you have hooked it up correct. Simply ensure that your motor is rotating correctly and set the RX series to monitor for any CHANGE in expected rotation from that point on.

F031 = Phase Rotation Trip Delay

Factory Setting = 2 seconds

Range = 1 - 20 seconds

Provides a time delay to prevent nuisance trips from short-duration transients. Using default settings, if the phase rotation is detected as different for more than 2 seconds after line voltage is first applied, the relay will trip. Use this delay when portable generators may provide erratic signals when first started up.

F032 = Phase Loss Trip and Delay

Factory Setting = 1 (second)

Range = 1 - 20 seconds, or 0 (Disabled)

When a value other than 0 is entered for F032, the relay will trip when the voltage of any phase is less than 20% of the nominal voltage set in F006 or F007 for this amount of time.

F033 = Over Frequency Trip Limit**Factory Setting = 0 (Disabled)****Range = 1 – 10Hz, or 0 (Disabled)**

When a value other than 0 is entered for F033, the relay will trip when the line frequency exceeds the amount set and for the time specified in F034. This feature is especially useful in generated power applications as backup protection to the generator's governor control.

F034 = Over Frequency Trip Delay**Factory Setting = 2 seconds****Range = 1 - 20 seconds**

Provides a time delay to prevent nuisance trips from short-duration transients. For example using default settings, if the line frequency exceeds the amount set in F033 for more than 2 seconds, the relay will trip.

F035 = Under Frequency Trip Limit**Factory Setting = 0 (Disabled)****Range = 1 – 10Hz, or 0 (Disabled)**

When a value other than 0 is entered for F035, the relay will trip when the line frequency exceeds the amount set and for the time specified in F036. This feature is especially useful in generated power applications as backup protection to the generator's governor control.

F036 = Under Frequency Trip Delay**Factory Setting = 2 seconds****Range = 1 - 20 seconds**

Provides a time delay to prevent nuisance trips from short-duration transients. Using default setting, if the line frequency drops below F035 for more than 2 seconds, the relay will trip.

5.6.5 Motor Power Protection Features

F037 – F043 set extended protection features that may be used in the **RX Series** relay. Percentages shown are all based automatically upon the Motor nameplate and line voltage information programmed into F001 and F006/7, along with calculate Power Factor to determine accurate motor loading. No additional calculations are necessary. Use these settings when it is necessary to take action based on true motor loading (HP or kW), which is more accurate than current alone because it will not fluctuate with line voltage conditions.



- **Note:**
All of these features are disabled at the factory and must be enabled via user programming as follows:

F037 = Motor kW Trip Setting

Factory Setting = 0 (Disabled)

Range = 1 – 4, or 0 (Disabled)

When a value other than 0 is entered for F035, the relay will trip according to the following settings:

1 = Over kW Trip. If the calculated motor load exceeds the trip point setting in F038 for the time set in F039, the relay will trip.

1 = Under kW Trip. If the calculated motor load drops below the trip point setting in F038 for the time set in F039, the relay will trip.

F038 = Motor kW Trip Point

Factory Setting = 50 (%)

Range = 20 – 100% of calculated motor full load kW rating

Motor rated power (kW) is calculated based upon E (from F006/7) x I from F001 x pf (measured) x SF (F002) x 1.732 (for 3 phase). Efficiency is assumed to be constant for these purposes. In determining the motor output kW value for comparison, E and I are measured by the relay.

F039 = Motor kW Trip Delay

Factory Setting = 1 minute

Range = 1 - 999 minutes

Provides a time delay to prevent nuisance trips from short-duration transients. Using default setting, if the motor kW drops below F038 for more than 1 minute, the relay will trip.

F040 = Power Factor Trip Range**Factory Setting = 0 (Disabled)****Range = 1 – 3, or 0 (Disabled)**

When a value other than 0 is entered for F040, the relay will trip according to the following settings:

1 = Trip on Lagging power factor. If the calculated motor power factor lags beyond the trip point setting in F041 for the time set in F042, the relay will trip.

2 = Trip on Leading power factor. If the calculated motor power factor leads beyond the trip point setting in F041 for the time set in F042, the relay will trip.

3 = Trip on Leading or Lagging power factor. If the calculated motor power factor lags or leads beyond the trip point setting in F041 for the time set in F042, the relay will trip.

F041 = Motor Power Factor Trip Point**Factory Setting = 0.50 (cosine θ)****Range = 0.01 – 1.0 calculated motor Power Factor**

Motor Power Factor (pf) is calculated based upon measured voltage and current waveforms

F042 = Motor Power Factor Trip Delay**Factory Setting = 2 seconds****Range = 1 – 20 seconds**

Provides a time delay to prevent nuisance trips from short-duration transients. Using default setting, if the motor pf moves outside of the settings in F041 in the direction set in F040 for more than 2 seconds, the relay will trip.

F043 = Motor Power Factor Current Direction**Factory Setting = 0 (normal)****Range = 0 or 1**

Provides a method to set the direction of current flow for measurement purposes.

5.6.6 Lockout Features

F044 – F046 provide lockout protection for motors and equipment that may have potentially damaging consequences from premature restart or with limited duty cycles. Time and count values for these lockouts can be viewed in F081 – F085. Time values are based on the Real Time Clock and DONOT reset when power is lost or disconnected. Emergency clearing of lockouts can be accomplished in F071.



WARNING!

When F044 through F046 are used with 2-wire control, the starter may re-start automatically when time has expired. Adequate warnings similar to those in Section 3.1.3.b should be observed.

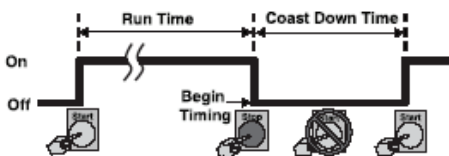

Figure 5.6.6:
Coast Down Lockout Timer

**F044 = Coast Down Lockout Timer (Back Spin Timer)
Factory Setting = 0 (Disabled)**

Range = 1 - 60 minutes, or 0 (Disabled)

When F044 = 1 through 60, this sets the number of minutes that the starter must be off before a restart can be attempted. This function is useful in applications such as pump motor backspin protection (where you need to prevent the pump motor from restarting if it is spinning backwards), 2 speed operations where speed changes require a minimum disconnect (spin-down timer), or reversing applications to prevent plugging (anti-plugging timer).

**F045 = Maximum Starts per Hour Lockout
Factory Setting = 0 (Disabled)**

Range = 1 – 10 or 0 (Disabled)

If F045=1 through 10, this feature will count the number of start commands within a 1 hour period. If the setting (maximum starts per hour) is exceeded, starting is prohibited until sufficient time has expired. This timer initiates upon the first start in an hour. It resets after 1 hour from that start and waits until another subsequent start to initiate again. (Often used in conjunction with F046).



▪ **Notes:**

- Consult the motor manufacturer for a “Starts-per-Hour” or “Starting Duty Cycle” rating. Larger motors tend to have lower starts-per-hour ratings.

F046 = Minimum Time Between Starts Lockout

Factory Setting = 0 (Disabled)

Range = 1 - 60 minutes, or 0 (Disabled)

When F046 is set to 1 through 60, the motor cannot be restarted within the time specified after the first start. Time between starts is calculated from the time of the first start command to the next regardless of run time or off time.

Example:

If F046 = 15, motor will not be allowed to re-start within 15 minutes of first start.

This function is useful as a “Short-Cycle Timer” in preventing excessive wear on motors where automatic demand control may occasionally cycle on and off too quickly, such as compressors or sump pumps

5.6.7 Output Relays

There are two programmable Output Relays (rated 240VAC, 5A, 1200 VA) in the **RX Series**. They can be programmed for change of state indication for any one of the 30 conditions identified in the following chart. Relays can be tested using **F111** (see section 5.6.18)

F047 = Aux Relay 1: Form A (SPST)

Factory Setting = 21 (Any Trip) + Fail Safe

Range = 1 - 26 (See list) (1-30 possible)

Use to program the desired operation for Relay # 1. This relay is pre-set as “Fail Safe” meaning that it is a Normally Open – Held Closed contact which re-opens when the programmed condition occurs. For this reason, Aux. Relay 1 should only be used for the first 26 Trip functions. See **F109** in section 5.6.17.

F048 = Aux Relay 2: Form C (SPDT), Standard Relay

Factory Setting = 28 (Start Command)

Range = 1 - 30 (See list)

Use to program the desired operation for Relay # 2.

| Setting | Relay Operation Description | Setting | Relay Operation Description |
|---------|------------------------------------|---------|-----------------------------------|
| 1 | Over Load During Start [OLA] | 16 | Ground Fault [GF] |
| 2 | Over Load Constant Speed [OLC] | 17 | Power Factor [PF] |
| 3 | Any Overload Trip [OLA or OLC] | 18 | KW Power Trip [Pr] |
| 4 | Voltage Imbalance [EI] | 19 | Phase Loss [PL] |
| 5 | Over Voltage [OE] | 20 | External Trip [Et] |
| 6 | Under Voltage During Start [UEA] | 21 | Any Trip (#1-#20) |
| 7 | Under Voltage Constant Speed [UEC] | 22 | Coast Down Time Inhibit [Cdt] |
| 8 | Phase Rotation [Rt] | 23 | Starts Per Hour Inhibit [SPH] |
| 9 | Over Frequency [OF] | 24 | Time Between Starts Inhibit [tbS] |
| 10 | Under Frequency [UF] | 25 | Any Inhibit |
| 11 | Current Imbalance [CI] | 26 | Any Trip or Inhibit |
| 12 | Over Current (Shear-Pin) Trip [OC] | 27 | Run Timer Engaged (F050) |
| 13 | Stall Detection [Sd] | 28 | Start Command (see below) |
| 14 | Peak Current (Short Circuit) [PC] | 29 | Motor Starting or Running Status |
| 15 | Under Current [UC] | 30 | Motor Running Status |

Note: For setting 28, “Start Command”, the relay will change state on the following conditions:
 1. External Digital Input AND Run Timer, if Run Timer engaged;
 2. External Digital Input ONLY, if Run Timer disabled.

Table 5.6.7: Output Relay Programming

5.6.8 Motor Running Detection Settings

The RX Series can be adjusted as to how it detects that a motor has finished accelerating. This can be useful when conditions in the application may interfere with the automatic detection method that is standard.

F049 = Motor Running Detection

Factory Setting = 0 (Auto)

Range = 1 – 180 sec., or 0 (Auto)

Setting 0 = Auto Sensing. The RX Series always monitors motor current. In this mode, At-Speed is determined by the current first going over 150% of the programmed FLA, then drops to a level below the FLA + Service factor.

Setting 1- 180 = Forced Timing. In this mode, the RX Series is forced into the Run state in this programmed amount of time OR based on Auto Sensing, whichever occurs first. This setting is useful when severely variable load conditions may interfere with auto-sensing because the current never drops low enough.

5.6.9 Process Timer Settings

F050 – F059 represent a Process Control Timer and Time Clock Controller that can be used in conjunction with Setting 28 (Start Command) of the Relay settings in F047 or F048 (see above). These capabilities are special enough to deserve a detailed description of operations and programming.

See Appendix B for complete details.

5.6.10 Communications

The **RX Series** relay is shipped from the factory ready to accept RS-485 Serial Communications using Modbus RTU protocol. Additional detailed instructions on accomplishing communications are available in a **Serial Communication Supplement** to this manual. F060 – F062 are used to set the communications parameters in the relay.

F060 = Remote Relay Control via Comm. Port

Factory Setting = 0 (disabled)

Range = 0 – 4

Use this to program how the **RX Series** relay is to be controlled when using serial communications.

When F060 = 0, Communications is disabled.

When F060 = 1, the relay can be monitored only by the Comm port, but not controlled. The Modbus RTU protocol uses an 11 bit format.

When F060 = 2, the relay can be monitored only by the Comm port, but not controlled. The Modbus RTU protocol uses a 10 bit format.

When F060 = 3, In this mode, a hard-wired Start command is put in “**AND**” logic with the Comm port; both Start commands must be on for the RX to allow a start. The Stop function is put in “**OR**” logic; either the Comm. Port Stop command **OR** the hard-wired Stop (removal of Start) will cause the RX to stop. This setting will work with 11 bit formats.

When F060 = 4, Same as above, except this setting will work with 10 bit formats.

F061 = Baud Rate

Factory Setting = 9.6 KB

Range = 4.8 to 19.2 KB

Set value to either 4.8 KB, 9.6 KB or 19.2 KB and match the setting of the host device.

F062 = Modbus Address

Factory Setting = 1

Range = 1 – 247

The Modbus communications protocol allows each node to have up to 247 connected devices but each must have a unique address. Two devices with the same address will result in a communications error.

5.6.11 External Input Settings.

The RX Series relay includes a dry contact input for external control or tripping.

F063 = External Input Control

Factory Setting = 0 (disabled)

Range = 1 – 2, or 0 (disabled)

A Dry contact input powered from an internal 6VDC source, so therefore should not be used for long distance relaying where voltage drop may become a problem. It can be programmed for the following functions:

0 = Disabled. The relay will not respond to the status of the External Input.

1 = Trip. When the External Input is closed (high), the Trip function of the relay will activate and the display will show “Et”

2 = Start Command. When the External Input is closed (high), the relay will respond to set one of the Output Relays to pass on a Start Command. This allows the **RX Series** relay to act as an interposing relay between low-voltage systems such as PLC relay outputs and 120V control systems.



▪ **Note:**

Use of the External Input requires coordinated programming of one or both Output Relays to match the functionality.

5.6.12 System Settings

The following functions set operator interface controls and unit programming. Also contained here are the Clock settings used for history functions. Change the Clock settings if accurate time values are important.

Real Time Clock Settings

Functions F064 through F069 set the system real time clock. The time clock is used in the 24hr Time Clock Controller operation (F050 – F059) and for date/time stamping of the Fault History. The clock automatically adjusts for leap years and is backed up with a Li battery for long life.



▪ **Note:**

Time clock does not automatically adjust for daylight savings time.

F064= Year

Factory Setting = Year of manufacture

Range = 2000 to 2047

F065 = Month

Factory Setting = Month of manufacture

Range = 1 – 12

F066 = Day
Factory Setting = Day of manufacture
Range = 1 – 31

F067 = Hour
Factory Setting = Actual (EST)
Range = 0 - 23 (12:00 midnight is hour 0)

F068 = Minute
Factory Setting = Actual (EST)
Range = 0 – 59

F069 = Second
Factory Setting = Actual (EST)
Range = 0 – 59

Pass Code protection

F070 = Level 1 Parameter Lock / User Password
Factory Setting = 0 (disabled)
Range = 0 – 999

Level 1 = Functions F001 through F071, + F109 and F111.

Use only when necessary to prevent unauthorized access.

Provides users with the ability to prevent unauthorized operators from making changes to the programmed functions. If you do NOT need to take advantage of this feature, do not enter anything into this function. The factory default is disabled, and no Password is necessary to make changes to the program.

See Appendix A at the end of this manual for detailed instructions on using and altering the Parameter Lock / User Password feature.

F071 = Emergency Clear / Reset
Factory Setting = 0 (disabled)
Range = 0 – 2

This Function serves two purposes. It can clear the memory values used for lockouts and overload protection, and it can reset all functions to the factory default settings. This is a “One-Shot” feature, so when another value is entered as shown below, this function automatically returns to the default state.

When F071 = 0, the feature is disabled.

When F071 = 1, the values stored in the Thermal Register and all of the Lockout Timers will be cleared. This will allow an **emergency restart** without having to wait for proper cool down time or lockout timers to expire.



WARNING!

Clearing the Thermal Register to allow restarting without proper cool-down time after an Overload Trip will risk motor damage and fire. Use only where emergency restart is necessary with knowledge of these potential hazards.

When F071 = 2, the values of all functions will be reset to the factory default settings. Use this feature when settings conflict or have been tampered with. This is also useful when you lose track of experimental settings and wish to start over. It will also be used to clear the Fault History.

When F071 = 3, The Watt-Hour metering (kWh) viewable in the Status Screen will be reset (cleared). Once cleared this information is not recoverable.



Note: F071 will not reset F070 or F072 = Parameter Lock / User Passwords. See Appendix A for resetting this feature.

F072 Level 2 Parameter Lock / User Password
Factory Setting = 0 (disabled)
Range = 2000 – 9999
Level 2 = Functions F071 through F108.

Use only when necessary to prevent unauthorized access. Provides users with the ability to prevent unauthorized operators from making changes to the programmed functions. If you do NOT need to take advantage of this feature, do not enter anything into this function. The factory default is ENABLED, and a Password is necessary to make changes to the program.

See Appendix A at the end of this manual for detailed instructions on using and altering the Parameter Lock / User Password feature.

5.6.12.a Unit Settings

F073 = CT Ratio:

Factory Setting = 40 (:5)
Range = 5 – 2000

Primary value of the **RX Series** internal Current Transformers (CTs) for use in determining the current flow through the relay. When using external CTs, set this value to the value of the external CT primary ratio. Default setting varies by unit frame size. To prevent meter burden from affecting protection systems, do not use the external CTs for metering. The RX relay Operator Panel can be mounted to the enclosure door for this purpose.

F074 = Number of Turns Through CT:

Factory Setting = 1
Range = 1 – 5

To achieve accurate readings on current values lower than 50% of the unit Max Amp rating, it is sometime necessary to pass the current through the CT windows more than once, referred to as “Turns” because the wire must turn to form a loop. The number of turns used must be entered here so that the display and protection systems will read the corrected amount.

F075 = PT Ratio:**Factory Setting = 1 (1:1)****Range = 1 (1:1) or 2 – 200:1 for kV input**

If the line voltage exceeds 600V, use a Potential Transformer to bring the applied voltage down to 120V or less on the RX Series relay terminals. When this is done, enter the PT ratio as a whole number into this function so that the displayed and calculated references are correct.

Example: 4160V motor application. $4160V \div 120V \text{ input} = 34.7:1 \text{ ratio}$

Use 40:1 PT so input voltage to relay is 120V or less (104V)

Enter "40" into F075 so that calculations are correct.

**Note:**

When a value other than 1 is entered into F075 the RX Series will automatically calibrate the display for kV reading, but the correct line voltage must also be entered into F007 for proper protection.

5.6.12.b Status Display

**F076 = Default Status Display:
Factory Setting = 2 (Phase A Current)
Range = 1 – 20**

The RX Series display can be scrolled through 20 different status display readouts as described in the following table. This function serves to allow the user to select which readout will be the default display that shows when first powered on and no scrolling has taken place. The factory Default is Phase A Current, which is indicated by both the readout and the LEDs that show what the readout means. The following table provides a list of the combination of readouts and LEDs that make up the list of 20 status display functions.

Status Display Screens

| Default No. (for F076) | Scroll Through Displays | Default No. (for F076) | Scroll Through Displays |
|---------------------------|----------------------------|---------------------------|--------------------------|
| #1 | Thermal Capacity Remaining | #11 | Voltage Imbalance % |
| #2 | Current in A Phase | #12 | Power Factor |
| #3 | Current in B Phase | #13 | kW |
| #4 | Current in C Phase | #14 | kVA |
| #5 | Average Current, 3 phases | #15 | KVAR |
| #6 | Current Imbalance % | #16 | kWh |
| #7 | Voltage AB | #17 | Frequency |
| #8 | Voltage BC | #18 | Ground Fault Current |
| #9 | Voltage CA | #19 | Process Time Remaining |
| #10 | Average Voltage | #20 | RTC clock (when engaged) |

Table 5.6.12.b: Status Display Screens

5.6.13 Auto Reset and Auto Restart Delay

5.6.13.a Auto Reset

The **RX Series** can be programmed to automatically attempt to reset after selected faults, provided a Start Command is present (see Section 4.2) and the fault condition has been corrected. The Fault Events to attempt resetting (F077) and Number of Reset Attempts on (F078) are programmable as follows.

**F077 = Auto-Reset on Selected Faults
Factory Setting = 4 (Phase Loss)
Range = 2 – 12 (code)**

If F077 = 2 through 12, the **RX Series** will attempt to restart after the fault(s) coded in the following table. Only one selection can be entered.

Continued next page...

Auto Reset Conditions

| F053 Setting | Fault Condition Description | Display Readout Reference |
|---------------------|------------------------------------|----------------------------------|
| 1 | Future Use | --- |
| 2 | Over Current (Shear Pin) Trip | OC |
| 3 | Under Current Trip | UC |
| 4 | Phase Loss Trip | PLa or PLc |
| 5 | Current Unbalance Trip | UB |
| 6 | Ground Fault Trip | GF |
| 7 | Peak Current Trip (Short Circuit) | PC |
| 8 | Faults 2 or 3 above | OC or UC |
| 9 | Faults 4, 5 or 6 above | PL, UB or GF |
| 10 | Any Fault except 7 | No PC |
| 11 | Any Fault except 6 & 7 | No GF and no PC |
| 12 | Any Fault above, 1 - 7 | OC, UC, PC, PL, UB or GF |

1. Note 1: UC, OC or UB require operation to resume before the fault can be detected.
 2. Note 2: Cycling and / or restoration of control power will reset all of the above faults.
 3. Note 3: Overload Trip reset function is programmed only in F005. See Section 3 for details
 4. Note 4: Reset attempts that occur when the fault condition is still present will cause a new fault. This will be logged into the fault history (F087 – F095) and may overwrite previous fault records.
 5. Attempted Reset interval is 2 minutes.
 6. Reset Attempt count will be refilled to setpoint value if RX has run twenty four hours without another trip

Table 5.6.13: Faults Selected for Auto-Reset



- **Note:**
Auto Reset and Auto Restart are separate functions!

F078 = Auto-Reset Attempts
Factory Setting = 0 (Disabled)
Range = 1 - 10 Attempts, or 0 (Disabled)

If F077 = 0 (default setting), the **RX Series** will not attempt to restart automatically.

If F077 = 1 through 10, the **RX Series** will attempt to restart if the Start Command is present for this number of times.

5.6.13.b Auto Restart after Power Failure

The **RX Series** can be programmed to delay restarting upon restoration of line power after an outage. This allows multiple units to be programmed to restart at staggered times in an effort to avoid causing additional problems with the power supply system. Another term for this is “**Sequential Start Delay**”.

F079 = Restart Delay Time

Factory Setting = 0 (Disabled)

Range = 0 = Disabled (no delay), or 1 - 999 seconds

Sets a delay time before the relay will allow restarting after a complete loss of power. Use this if multiple motors are connected to a supply system that may have trouble providing adequate power to restart them all at the same time. By using different Restart Delay Times on each unit, a sequential restart can be achieved.



- **Notes:**

- For Auto Restart to function on a Motor Starter, the RX Series must have Start Control of the starter using the Output Relay (typically Relay 2). See Section 5.6.7 for programming of Fn F047 and F048 for more details.
- F079 is similar to the Coast Down Lockout Timer in F044, however it only activates on Power Loss.
- When using 3 wire control:
For safety reasons the **RX Series** will not attempt restarting unless the Start Command is reinitiated and maintained during a restart attempt.

5.6.14 Factory Firmware**F080 = Firmware Record**

Factory Setting = Version Number (read only)

Have this information available when calling the factory for assistance that is not covered in this manual.

5.6.15 Timer Value Readouts for Protection Features

F081 – F086 provide display of timer or register values for information only. The user cannot alter them. Upon power loss and restoration, these values are updated for time elapsed.

F081 = Restart Delay Time Readout

Factory Setting = Not Applicable

Range = 0 - 999 Seconds

Remaining time value readout of F079, the Auto-Restart Delay Timer.

F082 = Coast Down (Backspin) Timer Value

Factory Setting = Not Applicable

Range = 1 - 3600 Seconds

Remaining time value readout of F045, the Coast Down Lockout Timer.

F083 = Starts per Hour Timer Value

Factory Setting = Not Applicable

Range = 1 - 3600 Seconds

Remaining time value readout of F049, the Starts-per-Hour Lockout Timer.

F084 = Starts per Hour Counter Readout

Factory Setting = Not Applicable

Range = 1 - 10 Starts

Incremental counter value readout of F045, the Starts-per-Hour Lockout.

F085 = Time Value Between Starts Readout

Factory Setting = Not Applicable

Range = 1 - 3600 Seconds

Remaining time value readout of F046, the Minimum Time Between Starts Timer.

F086 = Thermal Capacity to Start Readout

Factory Setting = Not Applicable

Range = 0 - 100 % Thermal Capacity

Readout only for user's viewing of the motor Thermal Capacity percentage required to allow a Reset after an Overload Trip (reference F005). Use this function in conjunction with the Remaining Thermal Capacity (**Hxxx** in the Status Screen group) to be able to predict when a restart will be allowed. This value is automatically updated by the **RX Series** CPU whenever a successful start sequence has been accomplished. The **RX Series** essentially "learns" how much Thermal Capacity is needed in the motor in order to successfully restart, and stores the information at this Function. Upon power loss and restoration, this value is updated for elapsed time.

5.6.16 Fault History and Statistical Data

F087 – F099 contain the Fault History and Statistical data about the Run Mode.

5.6.16.a Fault History

Fault codes for each of the three latest events are stored with time and date stamps; see Chapter 7 for a complete list of fault codes and corresponding error displays. They are stored in F087, 90 and 93.

Time stamps use the 24hr HH.MM format, so for example 3:19 PM would display as [15.19]. They are stored in F088, 91 and 94.

Date stamps use the MM.DD format, so for example September 3rd would display [09.03]. They are stored in F089, 92 and 95.

| | Fault #1 (Latest Fault) | Fault #2 (Previous Fault) | Fault #3 (Oldest Fault) |
|--|------------------------------------|--------------------------------------|------------------------------------|
| Fault code: (See Chapter 7) | F087 | F090 | F093 |
| Time Stamp (HH.mm) | F088 | F091 | F094 |
| Date Stamp (MM.DD) | F089 | F092 | F095 |

Table 5.6.16a: Fault History Configuration

F087 = Latest Fault Code (Fault #1)

Factory Setting = 0 (No Fault)

Range = 0 – 27

This Function displays the Fault Code of the latest fault event.

F088 = Time Stamp of the Latest Fault

Factory Setting = 00.00 (No Fault)

Range = 00.00 – 23.59 (24hr time format)

This Function displays the time of the latest fault event.

F089 = Date Stamp of the Latest Fault

Factory Setting = 00.00 (No Fault)

Range = 01.01 – 12.31

This Function displays the date of the latest fault event.

F090 = Same as F085 except for the Previous Fault (Fault #2)

F091 = Same as F086 except for the Previous Fault.

F092 = Same as F087 except for the Previous Fault.

F093 = Same as F085 except for the Oldest Fault (Fault #3)

F094 = Same as F086 except for the Oldest Fault

F095 = Same as F087 except for the Oldest Fault

5.6.16.b Statistical Data

F096 - F099 display information from the Run Time / Elapsed Time meter and Run-Cycle counter.

Run Time includes Accel, Run, Decel, and Jog operations, stored in F096 and F097.

Run Cycles are counted only when the relay reaches At-Speed mode, stored in F098 and F099.

F096 = Run Time, Hours
Factory Setting = 0000
Range = 000.9 - 999.9 hours
 Run counts in excess of 999.9 are recorded in F097.

F097 = Run Time, K Hours
Factory Setting = 0000
Range = 0000 - 9999 K hours
 0001 in readout means a run time of 1,000 hours.

F098 = Run Counts
Factory Setting = 0000
Range = 0000 – 9999
 Run counts in excess of 9999 are recorded in F099.

F099 = Run Counts, 10K Times
Factory Setting = 0000
Range = 0000 - 9999, 10 thousand times
 0001 in readout means a run count of 10,000 operations.

| Examples: | Overflow Value | Basic Value |
|-----------------------------|----------------|-------------|
| Run Time 23,047 Hours | F097 | F096 |
| | 0002 | 3047 |
| Run Counts 18,702 Starts | F099 | F098 |
| | 0001 | 8702 |

Table 5.6.16b: Statistical Data Examples

F096 through F108:
Reserved for Factory Use.

5.6.17 Relay 1 Fail Safe Programming

Relay 1 is designed to be used as a “Fail Safe” relay with a Normally Open contact. Fail Safe means it is a Held Closed contact when conditions are normal and will re-open when the programmed condition occurs (i.e. Any Trip). It also means that when power is Off, the relay state will revert to being Open. This function can be used to change Relay 1 to be a normal relay (Direct Acting), which would mean it is a NO contact that closes only when the programmed condition occurs.

F109 = Fail Safe Mode for Relay 1

Factory Setting = 1 (Relay is Fail Safe)

Range = 0 – 1

Use this function to alter the energized state of Relay 1 (**F047**).

F109 = 0, Disabled: The relay will become a normally operating relay (Direct Acting), meaning it will change state only when the programmed condition occurs.

F109 = 1, Enabled (default): The NO relay contact is held closed when conditions are normal (no trips) and drops out when a trip (or any other programmed condition) occurs, as well as a power failure.

5.6.18 Test Settings and Miscellaneous

F110 Keypad Firmware Version:

Factory Setting = Version Number (read only)

Have this information available when calling the factory for assistance that is not covered in this manual.

F111 = Relay Test:

Factory Setting = 0 (disabled)

Range = 1 – 2, or 0 (disabled)

Use this function to test (force) the Output Relays R1 and R2 to test their integrity. By entering a value into this function, the associated relay is forced to change state and will remain in that state until the Reset Button is pressed. Both relays can be forced. If this function is set to 0 and re-entered, the relay will reset as well, but if not, the relay will remain forced even if this function is used to force the other relay.

F111 = 1; Force Relay #1 (R1). Since this is a Form A (SPST) relay, the NO contact closes..

F111 = 2; Force Relay #2 (R2). Since this is a Form C (SPDT) relay, the NO contact closes and the NC contact opens



Note:

If the Relay is tripped and the trip condition continues to exist, this function cannot affect that relay until after the fault is cleared and it has been reset.



Warning

Relay testing may result in unwanted operation. Ensure that control circuits are disabled prior to testing the relay functions.

Chapter 6 - Start-up

6.1 Basic Startup

Your new **RX Series** Soft Relay is factory preset for a wide variety of applications and often can be used with minimal adjustment.

6.1.1 Three Step Process

1. Connect L1, L2, and L3 to power input and feed motor leads through (or to) CTs.
2. Connect control wires and control power.
3. Program motor FLA (F001) and Line Voltage (F006/7).

6.1.2 Start-up Parameters and Factory Defaults

Try the initial presets first and then adjust or enable the more advanced features to meet your specific starting needs.

| Fn # | Function Name | Factory Setting | Description / Factory Setting |
|-------------|--------------------------------------|-----------------------|--|
| F001 | Motor Nameplate FLA. | 0 | FLA must be programmed for relay to function. |
| F002 | Motor Nameplate Service Factor | 1.0 SF | Change only if necessary AND motor is rated over 1.0SF |
| F003 | Overload Class During Start | Class 10 | NEMA / UL Class 10 |
| F004 | Overload Class During Run | Class 10 | NEMA / UL Class 10 |
| F005 | Overload Reset | 0 (Manual) | 0 = Manual |
| F006/7 | Line Voltage | 480 | Enter Nominal line voltage (F007 = kV) |
| F008 | Frequency | 60 | Change if 50Hz |
| F0009 | Acceleration Time | 30 | Change only if longer is necessary |
| F010 - F021 | Current and Ground Protections | Off | Inactive unless selected |
| F022 - F029 | Voltage Protections | Off | Inactive unless selected |
| F030, F031 | Phase Rotation | A-B-C w/ 2 sec. delay | Change if necessary |
| F032 | Phase Loss Trip Delay | 2 seconds | Change as necessary |
| F033 - F036 | Frequency Trips | Off | Inactive unless selected |
| F037 – F043 | Motor Power Protections | Off | Inactive unless selected |
| F044 – F046 | Lockout Protections | Off | Inactive unless selected |
| F047 | Aux Relay #1 | 21 | Any fault |
| F048 | Aux Relay #2 | 28 | Run |
| F049 | Motor Running Detection | Auto | Change only if necessary |
| F050 – F059 | Process Timer and Time Clock Control | Inactive | Activate only if necessary |
| F060 – F062 | Communications | Inactive | Activate only if necessary |
| F063 | External Input | Inactive | Activate only if necessary |
| F064 – F076 | System settings and time clock | --- | User choice to adjust clock |
| F077 – F079 | Reset and Restart | Inactive | Activate only if necessary |
| F080 – F111 | Statistical data and Test functions | --- | View only |

6.2 Start-up Check List

- Supply voltage matches the rated supply voltage of the unit.
- Horsepower and current ratings of the motor and unit match
- Power lines are attached to the unit input terminals L1, L2 and L3.
- Motor leads are passed through the CT windows or connected to the adaptor. External CTs are connected to the adaptor if used.
- Appropriate control power is applied and/or control connections have been made.
- Four 7-segment LED readouts are visible.
- The motor's FLA has been programmed in function F001.
- Line voltage has been programmed into F006 (or F007 if kV)
- The thermal overload is properly set. (Use F003 and F004 to set OL Class.)
- The motor controller "coil circuit" is connected in such a way that the relay will drop it out on a trip. Test this by using F111.

Chapter 7 - Fault Conditions

Additional information on Fault Codes and possible causes can be found in the **Service and Troubleshooting Guide**.

7.1 Fault Codes and Numbers (in History)

A three-character fault code is displayed in the LED display at the time of the trip event. The first two digits indicate the trip condition (see Table 7.1). The third digit is a suffix showing the **RX Series** operating mode when the trip occurred. Operating modes are as follows:

Code suffix “A”: Acceleration, meaning that the **RX Series** was ramping up but had not yet achieved “At-Speed” status (see section 4.2.9.b for a brief description of At-Speed indication).

Code suffix “c”: Constant Speed (running), meaning that the **RX Series** has reach the At-Speed condition and the motor was running when the trip occurred.

Code suffix “d”: Decel or Stop, meaning that **RX Series** was either stopped (off, but power applied), or if the Pump-Flex Decel function was enabled, it was engaged in the Soft Stop routine set up by F024-27.

In addition to these fault display codes, each trip condition has a corresponding numeric code that is stored in the Fault History (see section 5.6.13.a). These numeric codes follow the display codes exactly. The following Table 7.1 shows Fault Display Codes, Fault Number Codes, LED indicators that would come on with them and descriptions. Additional details are available in the Service and Troubleshooting Guide.

Example: If Function F003 (starting overload protection) is set too low for the size of the load and causes a trip, the code “oLA” will be displayed. Its corresponding number will be entered into the fault history. In this case, the number 0010 will be available for display in the window of function F085 (Fault History). The time the fault was detected is available in Function F086. It is expressed as hh.mm. Therefore, if the “oLA” fault occurred at 10:00 am, F086 would display 10.00. The date the fault occurred is available in Function F087. The date is expressed as mm.dd. If the “oLA” fault occurred on March 1, F077 would display 03.01. If there were no fault conditions in history, the display in F085 would read 0000.

Fault Function Descriptions

| Fault Condition Description | Fault Display Code Readout | Fault Number Code used in History, F085, F088 and F091 | LED Indicator |
|--|----------------------------|--|---------------|
| No Full Load Amps entered into F001 | nFLA | | |
| Over Current during Acceleration | ocA | 1 | Trip |
| Over Current during Constant speed | occ | 2 | Trip |
| Over Current during Deceleration | ocd | 3 | Trip |
| Phase Loss during Acceleration | PLA | 4 | Trip |
| Phase Loss during Constant speed | PLc | 5 | Trip |
| Phase Loss during Deceleration | PLd | 6 | Trip |
| Over Load during Acceleration | oLA | 7 | Trip |
| Over Load during Constant speed | oLc | 8 | Trip |
| Over Load during Deceleration | oLd | 9 | Trip |
| Current Imbalance during Acceleration | IBA | 10 | Trip |
| Current Imbalance during Constant speed | IBc | 11 | Trip |
| Current Imbalance during Deceleration | IBd | 12 | Trip |
| Under Current during Acceleration | UcA | 13 | Trip |
| Under Current during Constant speed | Ucc | 14 | Trip |
| Under Current during Deceleration | Ucd | 15 | Trip |
| Ground Fault during Acceleration | GFA | 16 | Trip |
| Ground Fault during Constant speed | GFc | 17 | Trip |
| Ground Fault during Deceleration | GFd | 18 | Trip |
| Rotation Trip during Acceleration | rtA | 19 | Trip |
| Rotation Trip during Constant speed | rtc | 20 | Trip |
| Rotation Trip during Deceleration | rtd | 21 | Trip |
| Stall Detection During Accel | SDA | 22 | Trip |
| Stall Detection During Constant Speed | SDC | 23 | Trip |
| Stall Detection During Decel (or Stop) | SDD | 24 | Trip |
| Peak Current During Accel | PCA | 25 | Trip |
| Peak Current During Constant Speed | PCC | 26 | Trip |
| Peak Current During Decel (or Stop) | PCD | 27 | Trip |
| Voltage Imbalance During Accel | EIA | 28 | Trip |
| Voltage Imbalance During Constant Speed | EIC | 29 | Trip |
| Voltage Imbalance During Decel (or Stop) | EID | 30 | Trip |

Fault Function Descriptions (continued)

| Fault Condition Description | Fault Display Code Readout | Fault Number Code used in History, F085, F088 and F091 | LED Indicator |
|--|----------------------------|--|---------------|
| Over Voltage During Accel | OEA | 31 | Trip |
| Over Voltage During Constant Speed | OEC | 32 | Trip |
| Over Voltage During Decel (or Stop) | OED | 33 | Trip |
| Under Voltage During Accel | UEA | 34 | Trip |
| Under Voltage During Constant Speed | UEC | 35 | Trip |
| Under Voltage During Decel (or Stop) | UED | 36 | Trip |
| Over Frequency During Accel | OFA | 37 | Trip |
| Over Frequency During Constant Speed | OFC | 38 | Trip |
| Over Frequency During Decel (or Stop) | OFD | 39 | Trip |
| Under Frequency During Accel | UFA | 40 | Trip |
| Under Frequency During Constant Speed | UFC | 41 | Trip |
| Under Frequency During Decel (or Stop) | UFD | 42 | Trip |
| PowerR (kW) Trip During Accel | PRA | 43 | Trip |
| PowerR (kW) Trip During Constant Speed | PRC | 44 | Trip |
| PowerR (kW) Trip During Decel (or Stop) | PRD | 45 | Trip |
| Power Factor Trip During Accel | PFA | 46 | Trip |
| Power Factor Trip During Constant Speed | PFC | 47 | Trip |
| Power Factor Trip During Decel (or Stop) | PFD | 48 | Trip |
| Acceleration Time Trip During Accel | ACA | 49 | Trip |
| Reserved | | 50 | Trip |
| Reserved | | 51 | Trip |
| External Trip During Accel | EtA | 52 | Trip |
| External Trip During Constant Speed | EtC | 53 | Trip |
| External Trip During Decel (or Stop) | EtD | 54 | Trip |
| Reserved | | 55 | Trip |
| Reserved | | 56 | Trip |
| Reserved | | 57 | Trip |

Table 7.1: Fault code List

Appendix A: Parameter Lock / User Password Instructions

F070 and F072 provide users with the ability to prevent unauthorized operators from making changes to the programmed functions. **If you do not need to take advantage of this feature, do not enter anything into these functions.** The factory default is disabled, and no Password is necessary to make changes to the program. F070 locks out Functions F001 thru F069, F109 and F111. F072 locks out F0073 thru F108 and is factory set with a password. For simplicity, the following description refers to F070. To unlock F072, contact the factory for assistance but it will work in the same manner.

When any value other than 0000 is entered into this F070, the Parameter Lock is enabled and that number becomes the User Password. From that point forward, it will be necessary to enter the User Password in this Function prior to making changes in any programmed function, including this one. When the Parameter Lock has been enabled, attempts to alter the program will result in the display reading [Err] whenever the [READ/ENTER] key is pressed.

To alter the program after the Parameter Lock has been enabled, go to Function **F070** and enter the correct user Password. The display will read an encoded value representing the existing password. As soon as you press the first Arrow key, the display will change to [0000] and start showing the actual value of your password entry. When the [READ/ENTER] button is pressed, the display will read [PASS], indicating that the User Password is correct and the system is unlocked. You will have 5 minutes in which to make a change in the program. This 5 minute window resets whenever any key is pressed, so it floats to give you 5 minutes after the last entry. After 5 minutes of no keypad activity, the Parameter Lock is reinstated with the current user Password. Subsequent changes will require re-entering the User Password.

To change the User Password or to disable the Parameter Lock function, enter the programmed User Password first, then set Function F070 to 0, disabling the Parameter Lock. If you do not re-enter the Password or enter a new user password, the Parameter Lock feature will remain disabled. If you enter a different number into this Function, the new number becomes your new User Password. Existing passwords are encoded to “hide” them in the display.



Caution:

DO NOT LOSE YOUR PASSWORD.

If the password has been lost or forgotten, contact Motortronics for assistance.

Example: Figure App A

Enabling Password Protection / Parameter Lock

Starting from the Status Display Mode, no previous function number entered, no existing password...

Press the Fn key.

Displays F001 to indicate the beginning of the function list.

Press the LEFT arrow key

Selects the second digit (from the right). Note: do it in this order because F000 would not have been a valid number

Press the UP arrow key seven times (7X)

Changes the function code to F071.

Press the RIGHT arrow key

Selects the first digit (from the right).

Press the DOWN arrow key

Changes the function code to F070.

Press the Read Enter key

The default display will show [3552] as long as no password has been previously entered. This is the default code for "0000", meaning that there is no password. **As soon as you press the first Arrow key, the display will change to [0000]** and begin showing the actual value of your password entry. Any initial display other than [3552] signifies that a password already exists. This means that you will need to change, rather than enter a new one (see below).

Use the UP arrow and the LEFT arrow keys...

to display the password you desire (Valid range is 0000 to 0999). In this example, 0123 has been selected.

Press the Read Enter key

The display will flash [End] to confirm you have entered a password. Then it will return to displaying the Function #.

Example: Setting a Password

Using Password 123

| Press Key... | Display Shows... | Means... |
|--------------|------------------|----------------------------------|
| | 0000 | Phase A Current |
| Fn | F070 | Select Function #70 |
| READ ENTER | 3552 | Default Setting of Function #70 |
| ↑ x 3 | 0003 | New Value of First Digit |
| ← | 0003 | Cursor (flashing) Position Shift |
| ↑ x 2 | 0023 | New Value of Second Digit |
| ← | 0023 | Cursor (flashing) Position Shift |
| ↑ | 0123 | New Value of Second Digit |
| READ ENTER | End | Value Accepted (flashes once) |
| | F070 | Return to Function # Display |

Figure App 3:
Entering a Password

Changing passwords:

To change an existing password, the steps are essentially the same as outlined above, except you must first enter the existing password. At F070, press the [READ/ENTER] key to reveal the encoded password (you must know that password before it can be changed). Use the Arrow keys to enter the password. As soon as you press the first Arrow key, the display will change to [0000] and start showing the actual value of your entry. When you get to the existing password, press the [READ/ENTER] key again. The display will flash [PASS] to indicate that the password was accepted. If it flashes [Err], you have entered the wrong password.

Resetting to Factory Defaults using F071 will NOT reset the password.

Disabling Password Protection / Parameter Lockout

Changing function F070 to [0000] will disable the user password. If the initial display reads [3552], the password is already set to [0000].

Appendix B: Process Control Timer Functions

F050 through F059; Overview of Process Timer Control and Time Clock Controller Features:

The following special functions allow your **RX Series** relay to operate automatically from an internal Process Control Timer and Time Clock Controller (TCC) using a real time clock. The Process Control Timer (F050 and F051) can be used independently or together with the TCC feature (F032-39). The TCC requires using the Process Control Timer to provide for Start commands (depending on the selected mode). Time progression and clock values can be read in the Status Screen (see section 5.3.1).

A convenient chart at the end of this appendix shows all settings and interactions.

F050 = Process Control Timer Selection

Factory Setting = 0 (Disabled)

Range = 0, 1, 2

This function enables a **Process Control Timer**, which offers two operating modes (Minimum Batch Run Timer and Permissive Run Timer), selected by entering 1 or 2 here.

F050 = 1: Minimum Batch Run Timer

In this mode, the **Process Control Timer** engages that the motor will run for a minimum amount of time, regardless of whether someone stops it intentionally, or power fails and returns. When selected to Minimum Run Timer, it begins counting down after a Start command. The Time Value is set in **F051**. When the time value reaches **[0000]** the relay will turn off, even if the Start command is still closed and without a Stop command.

To **Reset** the timer in this mode, give a Stop command after the timer has expired. If using the TCC (F052), reset is automatic when completed and no other Run command is present.

If a Stop Command, power failure or Fault trip occurs during timed operation, the **Process Control Timer** is suspended and maintains its value. When the relay is then restarted, the timer resumes counting down to ensure that the motor has run for the programmed amount of time (finishes the batch).

Use this function to ensure that a load operates for a minimum amount of time regardless of other circumstances. **Examples** would be:

- **Irrigation pumps** where a specific amount of pumping time is required even if the pump is shut down on a low level alarm and then resets, or power fails and returns.
- **Mixers** that need to agitate for a specific amount of time yet may be shut down when power fails or as product is added.
- **Aeration Blowers** that must be run for minimum amounts of time to ensure that proper aeration (contact time) has been provided to a tank.

▪ **Note:**

In **2 wire control systems** where the Run command is maintained, the relay will automatically restart after a power failure or a Trip is reset. Use appropriate warnings as mentioned in section 3.1.3.b. (see the following F052 description for an exception to this).

In **3 wire control systems**, a new Start command will be required to restart the relay.



**Example: Figure App B.1
Minimum Run (Batch) Timer**

An irrigation pump needs to come on when called for by a soil moisture control system, and run for ½ hour. If during that ½ hour the well level drops and shuts the pump down, the pump needs to restart when the well recovers and finish the ½ hour pump time.

Set F050 to [0001] for Minimum Run Timer.

This will ensure that when the well level recovers and resets the run command, the relay will finish the time sequence.

Set F051 to [0030] (minutes)

This is the Run Time that ensures the proper amount of irrigation getting to the crop.

(Not Shown)

Ensure F052 is set to [0000] for One Shot

This will allow the Start command provided by the external control system to engage the relay at any time it is required.

(Another example of this function used with the Time Clock Controller is provided further on)

Example: Process Timer for Well Pump

| Press Key... | Display Shows... | Means... |
|--------------|------------------|---------------------------------|
| | F050 | Starting at Function #50 |
| READ ENTER | 0000 | Default Setting of Function #50 |
| ↑ | 0001 | Set F050 = 1 Minimum Run Timer |
| READ ENTER | End | Value Accepted (flashes once) |
| ↑ | F051 | Change to F051 |
| READ ENTER | 0000 | Default Setting of Function #51 |
| ← ↑ | 0030 | Change Setting to 30 minutes |
| READ ENTER | End | Value Accepted (flashes once) |
| | F051 | Return to Function # Display |

Cycle Control Power to Accept Changes

Figure App B.1:
Programming the Minimum Run Timer Functions

▪ **Notes on interactions with other functions:**

When used with F079 (Auto-Restart Delay), the Minimum Batch Timer will not resume counting down until F079 has expired and the relay has been restarted. When used with **3 wire control**, it may be necessary to maintain a Start Command until after F079 has expired, or repeat it if momentary.

When used with F044 – F046 (Lockout Protection features), the Minimum Batch Timer will not resume counting down until those settings have been satisfied and the **RX Series** relay has restarted. When used with **3-wire control**, it may be necessary to maintain a Start Command until after they are satisfied, or repeat it if momentary.

F050 = 2: Permissive Run Timer.

In this mode, the **Process Control Timer** engages differently according to the settings of the Time Clock Controller (TCC).

When the TCC is set to 0 (using “One Shot” operation), the Process Control Timer begins counting down after the first Start command. Subsequent stop and start commands have no further affect on the timer status and can be used to fully control the relay. When the timer finishes (F051 = **[0000]**), the relay will shut off. Upon the next Start command, the timer will reset and begin counting down again. In 2 wire control systems, the relay will shut off even if the Run command is still closed, and will only reset after the Run command has been cycled (opened and reclosed).

Use this function in *without* the Time Clock Controller (One-Shot mode) to ensure that a load only operates *for a maximum* of the programmed amount of time, beginning with the first Start command. **Examples** would be:

- **Pumps** where the failure of a stop float may lead to dry run conditions if allowed to operate too long, or when the pump only needs to run when someone is present, but operate automatically via float switched (pump-out for service).
- **Ventilation Blowers** where operation is controlled by a manual switch but may be inadvertently left on when someone leaves.

When the TCC is set for 1 through 8 (using Start Event Cycles), the timer begins counting down immediately **when a Start Event is activated**. Any Start / Stop Command that is given to the relay during this time will work normally. When the timer finishes (F051 = **[0000]**), the relay will shut off, and **Start / Stop commands will no longer function until the next Start Event Cycle (SEC)**. In 2 wire control systems, If a Run command is already present when the SEC occurs, it will make no difference and the relay will start.

Reset of the **Permissive Run Timer** will occur only when the next Start Event Cycle is activated by the Time Clock Controller, or when changes are made to programming (see note on programming changes (see “Important Note” on page 73). Loss of control power without program changes will NOT reset the time.

Use this function in conjunction with the Time Clock Controller to ensure that a load only operates during the programmed amount of time, beginning with the Start Event Cycle. **Examples** would be:

- **Air compressors** where leaking of air lines during normal downtime causes the compressor to run unnecessarily
- **Irrigation pumps** where operation during parts of the day is undesirable.
- **Energy Savings** to prevent operation when Time-of-Use (TOU) metering discounts are provided to promote conservation.

**Example: Figure App B.2
Permissive Run Timer**

An air compressor controlled by a pressure switch feeds a large air distribution system that has small normally insignificant leaks. If left on over night when the system is not in use, leaks drop the air pressure and the compressor cycles on and off even though the facility is unoccupied, wasting energy.

Set F050 to [0002] for Permissive Run Timer.

This will ensure that if nobody remembers to shut the compressor off, it will not run when the facility is shut down.

Set F051 to [0600] minutes (10 hours)

This is the longest Run Time after which the relay will automatically shut down. This ensures that it will not restart after the time expires and until a new Start Event occurs.

(Not Shown)

Ensure F052 is set to [0001] for Every Day, and F053 is set to correspond to work start time (or 5 minutes prior)

This will allow the Run command provided by the pressure switch to engage the relay any time it is required after the shift begins.

With this setting, the compressor will start whenever the pressure switch calls for it after the Start Event set by the Time Clock Controller, but if forgotten it will shut itself off after 10 hours. If power is turned off or lost during those 10 hours, the timer is not cleared or reset, so even if it is turn back on 1 minute before the timer expires, it still shuts off at the end of that 10 hour period.

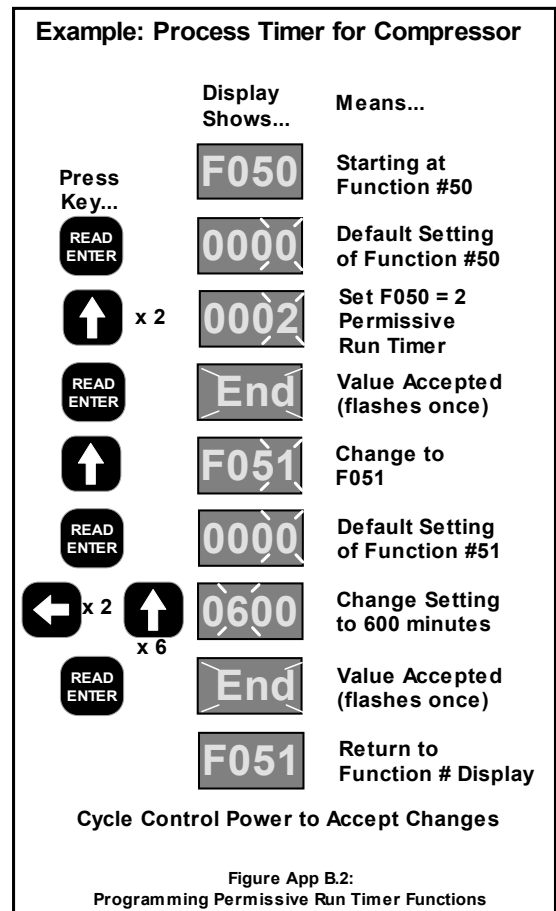

Notes:



If the **Process Control Timer** (F050) is set for Minimum Batch Timer (value of 1), and the next Start Event Cycle passes without a Start command, the previous event will be ignored in favor of the new one.

If a **Process Control Timer** setting from F051 is so long that it overlaps a Start Event Cycle setting in F052-F059, the original timer value becomes invalid. The new Start Event Cycle reloads the value of F051 and begins counting down again from the beginning.

F051 = Process Timer Value

Factory Setting = 1

Range = 1 – 9999 minutes

This function loads a value into the **Process Control Timer** above. When initialized, the value counts down towards 0.

F050 sets the operating mode and reset functions for this timer:

The value of this timer can be read directly in the main Status Screen (see section 5.3.1). When the **Process Control Timer** has been enabled in F050, the Status Screen display for the value will flash once per second while timing. When completed, it will stop flashing and read [0000].



- **IMPORTANT NOTE:** When F050 or F051 is changed in program mode, the timer will not respond to the new settings until after control power has been cycled (off and back on again).

F052 = Time Clock Controller (TCC)

Factory Setting = 0 (One Shot)

Range = 1 - 8 settings

This function is used to select the operating mode of the 24hr / 7 Day **Time Clock Controller (TCC)**.

F052 = 0 operates the SEC in a “One-Shot” mode (factory default setting). When set to 0, the Process Timer (F050) responds only to each **NEW** hard-wired Start input command. **Use this setting to allow the Process Control Timer to operate without the TCC.**

For automatic operations, F052 can also set the number of days in which the TCC will repeat a **Start Event Cycle (SEC)**. Each Start Event Cycle consists of from 1 to 7 Start Events as programmed in F053 through F059 below. Start Events can be non-sequential (see Note below).

F052 = 1 operates the SEC every day of the week.

F052 = 2 operates the SEC every 2 days (every other day)

F052 = 3 operates the SEC every 3rd day.

F052 = 4 operates the SEC every 4th day.

F052 = 5 operates the SEC every 5th day.

F052 = 6 operates the SEC every 6th day

F052 = 7 operates the SEC 1 day per week.

F052 = 8 operates the SEC for a single 24HR event, non-repeating. Use this for testing or for “walk away” operations that need to run after you leave but not again.

Start Event Cycles allow the use of a Start Command (2-wire or 3-wire) **ONLY AFTER** the time of the Start Event has passed (logic state AND). In a 3-wire control system, this is similar to having an Enable switch in series with the Stop button. In a 2-wire control system, this is similar to having an Enable contacts in series with the Run contact. The Stop Button (or opening the Run contact) will always work to shut down the **RX Series** relay. If F052 is set to anything other than 0, the normal Start – Stop functions will not longer work except as shown above.

Each Start Event is a timed operation based on the Process Timer settings in F030 above.



Important:

If F050 = 0 (Disabled), the TCC will be ignored. So if F052 = 1-8 and F050 = 0, the relay will not operate!

Make sure that if F030 = 0, F052 = 0 as well.

F053 = Event #1 Start Time**Factory Setting = OFF****Range = 00:00 through 23:59, or OFF**

This function is used to select the start time for Event #1 in the TCC above. Once given a Start command after this event time, the relay will run the motor according to the selections entered into F050 and for the time entered into F051.

F054 = Event #2 Start Time Same as above, except for event #2**F055 = Event #3 Start Time** Same as above, except for event #3**F056 = Event #4 Start Time** Same as above, except for event #4**F057 = Event #5 Start Time** Same as above, except for event #5**F058 = Event #6 Start Time** Same as above, except for event #6**F059 = Event #7 Start Time** Same as above, except for event #7▪ **Note:**

Start Events are completely independent of one another, and can be programmed in any order. For instance, the Start Time in F057 can be earlier than the Start Time in F053. This allows easier alterations or additions of new Start Times after a unit is already installed.

| Fn# | Function Type | Setting | Function Description / Range | Timer Initiated By... | Motor Starts When... | Motor Stops When... | Timer Reset When... | | |
|--|---|----------------|--|---|----------------------|-------------------------------------|--------------------------------------|--|--------------------------------------|
| F050 | Process Control Timer Mode | 0 | No Process Control Timer operation (default setting from factory) | | | | | | |
| | | 1 | Minimum (Batch) Run Timer (works the same with or without TCC control) | Start command and/or TCC | Start command | Time Expires, Trip, or Stop Command | Time Expires + Stop command only | | |
| | | 2 | Permissive Run Timer, without TCC (F052 = 0, "One Shot") | Start command | Start command | | Time Expires | | |
| Permissive Run Timer, with TCC (F052 = 2 thru 8) | TCC Start Event only | | Next SEC only | | | | | | |
| F051 | Process Timer Value | Run Time Value | Timer value setting used by F050 Range: 1 – 9999 minutes (166.65 hours) | --- | --- | | Per F050 setting | | |
| F052 | 24 hr / 7 day Time Clock Controller | 0 | One-Shot, follows Start command only | Start command | Start command | Per F050 setting | Per F050 setting | | |
| | | 1 | Loop the Start Even Cycle (SEC) daily | 24hr Real Time Clock on day of program change | | | | | Continuous unless program is changed |
| | | 2 | Loop the 24hr SEC every other day | | | | | | |
| | | 3 | Loop the 24hr SEC every 3 rd day | | | | | | |
| | | 4 | Loop the 24hr SEC every 4 th day | | | | | | |
| | | 5 | Loop the 24hr SEC every 5 th day | | | | | | |
| | | 6 | Loop the 24hr SEC every 6 th day | | | | | | |
| | | 7 | Loop the 24hr SEC one day per week | | | | | | |
| 8 | Single 24hr SEC, without repeating (until programmed again) | | Change of Program | | | | | | |
| F053 | Event #1 | Start time | 24hr TCC Start Time for Event #1 | F052 = 1-8 | Per F050 setting | Per F050 setting | Continuous unless program is changed | | |
| F054 | Event #2 | Start time | 24hr TCC Start Time for Event #2 | | | | | | |
| F055 | Event #3 | Start time | 24hr TCC Start Time for Event #3 | | | | | | |
| F056 | Event #4 | Start time | 24hr TCC Start Time for Event #4 | | | | | | |
| F057 | Event #5 | Start time | 24hr TCC Start Time for Event #5 | | | | | | |
| F058 | Event #6 | Start time | 24hr TCC Start Time for Event #6 | | | | | | |
| F059 | Event #7 | Start time | 24hr TCC Start Time for Event #7 | | | | | | |

Chart APP B.1 Process Timer and TCC Operations Logic Chart



▪ **Note:**

These functions may interact with the Coast Down Lockout (F044), Stars-per-Hour Lockout (F045), Minimum Time Between Starts (F046), Auto Reset (F078) and Restart Delay Time (F079) functions if enabled. Be sure to read and understand descriptions of those functions, then check settings before using the **Process Control Timer**.

**Example: Figure App B.3
Time Clock Controller with Minimum Run Timer**

An irrigation pump fed from a well with a single float level control needs to come on every other day at 5:30 PM, and run for ½ hour. If during that ½ hour the well level drops and shuts the pump down, the pump needs to restart when the well recovers and finish the ½ hour pump time.

Set F050 to [0001] for Minimum Run Timer.

This will ensure that when the well level recovers and resets the run command, the relay will finish the time sequence.

Set F051 to [0030] (minutes)

This is the Batch Time that ensures the proper amount of irrigation getting to the crop.

Set F052 to [0002] for Every 2nd Day

This will begin the Start Even Cycle on the day of programming and every other day from then on.

Set F053 to [17.30]

This is the 24HR time value representing 5:30 PM. At this time, every other day, the **RX Series** relay will automatically start (provided the Stop float in the well is closed) and run for 30 minutes as programmed in F030.

If the pump needs to come on again at 7:00 PM, program F054 to [19.00]. If later on it is needed to come on at 6:00 AM as well, simply change any other unused start time, i.e. F058 to [06.00]. Even though this is Event #6 and the lower numbered events had later start times in the program, the relay will execute #6 on time in the next available cycle.

If the pump needs to come on every day, program F052 to [0001].

Example: Process Timer and TCC for Irrigation Pump

| Press Key... | Display Shows... | Means... |
|--------------|------------------|-------------------------------------|
| | F050 | Starting at Function #50 |
| READ ENTER | 0000 | Default Setting of Function #50 |
| ↑ | 0001 | Set F050 = 1 Min. Batch Timer |
| READ ENTER | End | Value Accepted (flashes once) |
| ↑ | F051 | Change to F051 |
| READ ENTER | 0000 | Default Setting of Function #51 |
| ← ↑ x 3 | 0030 | Change Setting to 30 minutes |
| READ ENTER | End | Value Accepted (flashes once) |
| ↑ | F052 | Change to F052 |
| READ ENTER | 0000 | Default Setting of Function #52 |
| ↑ x 2 | 0002 | Set to 2: Every 2 nd Day |
| READ ENTER | End | Value Accepted (flashes once) |
| ↑ | F053 | Change to F053 |
| ← ↑ | 17.30 | Set to 17.30 (5:30 PM military) |
| READ ENTER | End | Value Accepted (flashes once) |
| | F053 | Return to Function # Display |

Cycle Control Power to Accept Changes

Figure App B.3: Programming Timer Functions



Note:

If programming is entered AFTER the set time value, the TCC will wait until the next valid time before executing (i.e. if you entered the above example program changes at 5:35 PM, the pump would not come on automatically until 5:30 PM 2 days from now).

Appendix C - Relay Settings Record

The following chart may be used to record the changes made to the factory settings.

| Fn # | Group | Function Description | Adjustment / Display Range | Setting Increments | Factory Setting | Setting | Setting |
|------|-------------------------------------|--|---|--------------------|-----------------|---------|---------|
| F001 | Motor and Overload Info. | Motor Nameplate FLA FLA must be programmed for relay to function. | 50-100% of Max Amp Rating. Upper limit of range automatically adjusts downward as Service factor is increased. | 1 amp | 0 | | |
| F002 | | Motor Nameplate Service Factor | 1.00 - 1.30 SF | 0.05 | 1.0 SF | | |
| F003 | | Overload Class During Start | NEMA / UL Class 5 - 30 | 5 | Class 10 | | |
| F004 | | Overload Class During Run | NEMA / UL Class 5 - 30 | 5 | Class 10 | | |
| F005 | | Overload Reset | 0 = Manual 1 = Auto 2 = Disabled Overload | 1 | 0 (Manual) | | |
| F006 | | Voltage Input (nominal Line) | 200 – 600 volt | 1 | 480 | | |
| F007 | | kV Voltage Input (nominal line, Medium Voltage) | .60 – 15kV | .01 | 4.16 | | |
| F008 | | Line Frequency | 50 or 60 Hz | - | 60 | | |
| F009 | | Acceleration Time | 0-300 seconds [0=Disabled] | 1 | 30 | | |
| F010 | Current and Ground Fault Protection | Current Imbalance Trip % | 0, 1 - 30% of FLA [0=Disabled] | 1(%) | 0 | | |
| F011 | | Current Imbalance Trip Delay | 1 - 20 seconds | 1(Second) | 2 | | |
| F012 | | Over Current Trip % | 0, 50 – 300% of FLA [0=Disabled] | 1(%) | 0 | | |
| F013 | | Over Current Trip Delay | 1 - 20 seconds | 1 | 1 | | |
| F014 | | Under Current % | 0, 10 – 90% of FLA [0=Disabled] | 1(%) | 0 | | |
| F015 | | Under Current Trip Delay | 1 - 60 seconds | 1 | 2 | | |
| F016 | | Stall Detection Trip Level | 0, 100 – 600% of FLA [0=Disabled] | 5(%) | 0 | | |
| F017 | | Stall Detection Trip Delay | 1 - 10 seconds | 1 | 2 | | |
| F018 | | Peak Current Trip % | 0, 800 – 1400% [0=Disabled] | 10(%) | 1000 (%) | | |
| F019 | | Peak Current Trip Delay | 0, .01 - .5 seconds | .01 | .05 | | |
| F020 | | Ground Fault Current Trip Value | 0, 5 – 90% of CT Value [0=Disabled] | 1(%) | 0 | | |
| F021 | Ground Fault Current Trip Delay | 1 – 60 seconds | 1 | 2 | | | |
| F022 | Voltage Protection | Voltage Imbalance Trip % | 0, 1 – 30% [0=Disabled] | 1(%) | 0 | | |
| F023 | | Voltage Imbalance Trip Delay | 1 – 20 seconds | 1 | 10 | | |
| F024 | | Over Voltage Trip % | 0, 1 – 10% [0=Disabled] | 1(%) | 0 | | |
| F025 | | Over Voltage Trip Delay | 1 – 20 seconds | 1 | 10 | | |
| F026 | | Under Voltage Trip on Start % | 0, 1 – 20% [0=Disabled] | 1(%) | 0 | | |
| F027 | | UV Trip on Start Delay | 1 – 180 seconds | 1 | 10 | | |
| F028 | | Under Voltage Trip on Run % | 0, 1 – 20% [0=Disabled] | 1(%) | 0 | | |
| F029 | | UV Trip Delay during Run | 1 – 20 seconds | 1 | 2 | | |

Appendix C (cont.) Soft Relay Settings Record

| Fn # | Group | Function Description | Adjustment / Display Range | Setting Increments | Factory Setting | Setting | Setting |
|------|--------------------------------|--------------------------------------|---|--|-----------------|---------|---------|
| F030 | Phase and Frequency Protection | Phase Rotation Trip | 0, 1 or 2 0=Disabled, 1=ABC, 2=ACB] | 1 | 1 | | |
| F031 | | Phase Rotation Trip Delay | 1 – 20 seconds | 1 | 2 | | |
| F032 | | Phase Loss Trip and Delay | 0, 1-20 Seconds [0= Disabled] | 1 | 1 | | |
| F033 | | Over Frequency Trip Limit | 0, 1 – 10Hz [0=Disabled] | 1 | 0 | | |
| F034 | | Over Frequency Trip Delay | 1 – 20 seconds | 1 | 2 | | |
| F035 | | Under Frequency Trip Limit | 0, 1 – 10Hz [0=Disabled] | 1 | 0 | | |
| F036 | | Under Frequency Trip Delay | 1 – 20 seconds | 1 | 2 | | |
| F037 | | Power Protection | Motor KW Trip | 0-2 0 = Disabled 1 = Over KW Trip 2 = Under KW Trip | 1 | 0 | |
| F038 | Motor KW Trip Point | | 20 – 100% of full load KW | 1% | 50(%) | | |
| F039 | Motor KW Trip Delay Time | | 1 – 999 minutes | 1 | 1 | | |
| F040 | Power Factor Trip Range | | 0, 1 – 3 [0=Disabled, 1=l原因, 2=lead, 3= lead/lag] | 1 | 0 | | |
| F041 | Power Factor Trip Point | | .01 – 1 (cos. Θ) | .01 | .50 | | |
| F042 | Power Factor Trip Delay Time | | 1 – 20 seconds | 1 | 2 | | |
| F043 | Power Factor Current Direction | | 0 - 1, [0=Normal, 1= Reversed] | 1 | 0 | | |
| F044 | Lockouts, and Inhibits | Coast Down (Back Spin) Lockout Timer | 0 = Disabled, or 1 - 60 minutes | 1 minute | 0 | | |
| F045 | | Maximum Starts per Hour | 0 = Disabled, or 1 – 10 starts | 1 | 0 | | |
| F046 | | Minimum Time Between Starts Inhibit | 0 = Disabled, or 1 - 60 minutes | 1 minute | 0 | | |

Appendix 6 (cont.) Soft Relay Settings Record

| Fn # | Group | Function Description | Adjustment / Display Range | Setting Increments | Factory Setting | Setting | Setting |
|------|---|--|---|--------------------|-----------------|---------|---------|
| F047 | Output Relays | Aux Relay 1 setting | Operation # 1 – 30: see chart | 1 | 21 | | |
| F048 | | Aux Relay 2 setting | Operation # 1 – 30: see chart | 1 | 28 | | |
| F049 | Motor State | Motor Running Detection | 0, or 1-180 seconds 0 = Auto sensing. Current > 150% FLA first and then drop< FLA x Service Factor 1-180 sec. = Force to Run status after given delay time OR Auto sensing, whichever occurs first | 1 | 0 | | |
| F050 | Run Timer and Time Clock Controller Modes | Run Timer Selection | 0 = Disabled (No timer operation) 1 = Minimum (Batch) Run Timer 2 = Permissive Run Timer | 1 | 0 Disabled | | |
| F051 | | Run Timer Time for use in F030 above | 1-9999 minutes after a Start Command or Start Event from TCC | 1 | 1 | | |
| F052 | | 24hr Time Clock Controller (TCC) Start Event Mode. | Start Event Cycle (SEC) Settings. See chart | 1 | 0 One Shot | | |
| F053 | | Start Event #1 Start Time | 00:00-23:59 (hh:mm) or OFF | 1 | OFF | | |
| F054 | | Start Event #2 Start Time | 00:00-23:59 (hh:mm) or OFF | 1 | OFF | | |
| F035 | | Start Event #3 Start Time | 00:00-23:59 (hh:mm) or OFF | 1 | OFF | | |
| F056 | | Start Event #4 Start Time | 00:00-23:59 (hh:mm) or OFF | 1 | OFF | | |
| F057 | | Start Event #5 Start Time | 00:00-23:59 (hh:mm) or OFF | 1 | OFF | | |
| F058 | | Start Event #6 Start Time | 00:00-23:59 (hh:mm) or OFF | 1 | OFF | | |
| F059 | | Start Event #7 Start Time | 00:00-23:59 (hh:mm) or OFF | 1 | OFF | | |
| F060 | Communications | Communications | Range: 0 – 4 0 = Disabled; 1 = Enabled (11 bit format) 2 = Enabled (10 bit format) 3 = Enabled (11bit) and Remote Start Control; 4 = Enabled (10bit) and Remote Start Control. | 1 | 0 | | |
| F061 | | Baud Rate | 4.8, 9.6 and 19.2 KB | 3 rates | 9.6 KB | | |
| F062 | | Modbus Address | 1 - 247 | 1 | 1 | | |
| F063 | External Input Control | External Dry Contact Input | Setting Range: 0-2 0 = Disabled; 1 = External Trip Input; 2 = Start Button Input Note: Start Button Input must be enabled while Run Timer or Remote Start Control is selected. | 1 | 0 | | |

Appendix 6 (cont.) Soft Relay Settings Record

| Fn # | Group | Function Description | Adjustment / Display Range | Setting Increments | Factory Setting | Setting | Setting |
|------|---|---|--|---|-----------------------------------|-----------------------|---------|
| F064 | System Settings | Year | 2000 - 2047 | 1 year | 2000 | | |
| F065 | | Month | 1 - 12 | 1 Month | 1 | | |
| F066 | | Day | 1 - 31 | 1 Day | 1 | | |
| F067 | | Hour | 0 - 23 | 1 Hour | 0 | | |
| F068 | | Minute | 0 - 59 | 1 Minute | 0 | | |
| F069 | | Second | 0 - 59 | 1 Second | 0 | | |
| F070 | | Parameter Lock Customer Level 1 Password | 0 – 999 0 = Disabled Any Other Numbers = Password Note: Level 1 = Fn 0001 thru 0071 | 1 | 0 (displays encrypted code) | | |
| F071 | | System Clear / Reset | 0 = Disabled 1 = Clear THR and Lockout Timers 2 = Reset to Factory Default Settings | 1 | 0 | | |
| F072 | | Parameter Lock Customer Level 2 Password | 2000 – 9999 Enabled Note: Level 2 = Fn 0071 thru 0108 | 1 | 2000 (displays encrypted code) | | |
| F073 | | CT Value | 5-2000 (:5) | 5 | 50 | | |
| F074 | | Number of Turns through CT | 1 – 10 | 1 | 1 | | |
| F075 | | PT Value | 1-200 (: 1) 1:1 = direct voltage input, 2-200:1 = kV Voltage Input | 1 | 1 | | |
| F076 | | Default Status Display | 2 – 20 (see Table) | 1 | 2 | | |
| F077 | | Auto Reset and Restart | Auto Reset on Selected Faults | Fault Preferences 1 – 12 See Table 5.6.13: "Auto-Reset Selected Faults" | 1 | 4, Phase Loss only | |
| F078 | Auto Reset Attempts | | 0 = Disabled, or 1-10 attempts | 1 | 1 | | |
| F079 | Restart Delay Time (Sequential Start Delay) | | 0 = Disabled, or 1-999 seconds after a Power Loss (Status can be read in F081) | 1 second | 0 | | |
| F080 | | Firmware Revision Number | | | | | |
| F081 | Inhibit Timer and Counter Values | Restart Delay Time Value Readout (for F079) | 0-999 Minutes | 1 | 0 | | |
| F082 | | Coast Down Timer Value for F044 | 1-3600 Seconds | 1 | 0 | | |
| F083 | | Starts Per Hour Timer Value for F045 | 1-3600 Seconds | 1 | 0 | | |
| F084 | | Starts Per Hour count For F045 | 1-10 Starts | 1 | 0 | | |
| F085 | | Time Value Between Starts for F046 | 1-3600 Seconds | 1 | 0 | | |
| F086 | | Thermal Capacity to Start for F005 | 0-100 % Thermal Capacity | 1 | 0 | | |

| Fn # | Group | Function Description | Adjustment / Display Range | Setting Increments | Factory Setting | Setting | Setting |
|----------------|--------------------------------------|--|---|--------------------------------|--------------------------------|---------|---------|
| F087 | Fault History and Run Data | Fault History #1, Latest Fault | 0 = No fault history, or Fault # 1 - 27: see Fault code list | 1 | 0 (displays encrypted code) | | |
| F088 | | Time Stamp, Fault #1 Based on F067-69 | 00.00-23.59 (hh.mm) [hh = 00-23; mm = 00-59] | 00.01 | | | |
| F089 | | Date Stamp, Fault #1 Based on F064-66 | 01.01 – 12.31 (MM.DD) [MM = 01-12; DD = 01-31] | 00.01 | | | |
| F090 | | Fault History #2, Previous Fault | 0 = No fault history, or Fault # 1 - 27: see Fault code list | 1 | | | |
| F091 | | Time Stamp, Fault #2 | 00.00-23.59 (hh.mm) [hh = 00-23; mm = 00-59] | 00.01 | | | |
| F092 | | Date Stamp, Fault #2 | 01.01 – 12.31 (MM.DD) [MM = 01-12; DD = 01-31] | 00.01 | | | |
| F093 | | Fault History #3, Oldest Fault | 0 = No fault history, or Fault # 1 - 27: see Fault code list | 1 | | | |
| F094 | | Time Stamp, Fault #3 | 00.00-23.59 (hh.mm) [hh = 00-23; mm = 00-59] | 00.01 | | | |
| F095 | | Date Stamp, Fault #3 | 01.01 – 12.31 (MM.DD) [MM = 01-12; DD = 01-31] | 00.01 | | | |
| F096 | | Run Time, Hours | 000.0 – 999.9 hours | 0.1 hours | 50 | | |
| F097 | | Run Time, 1000 Hour Overflow | 0000 – 9999 thousand hours | 1 k-hour | 1 | | |
| F098 | | Run Cycle Counter | 0000 – 9999 times | 1 times | 1 | | |
| F099 | | Run Cycle Counter 10K overflow | 0000 – 9999 10 thousand times | 10k times | 2 | | |
| F100 thru F108 | | Test Functions | Reserved for Factory Use | No adjustment or valid display | | | |
| F109 | Fail Safe Operation for Aux. Relay 1 | | 0 – 2 0 = Relay operates in Normal Mode (Direct Acting) 1 = Relay operates in Fail Safe mode (NO Held Closed, Open on Trip) | 1 | 1 (Fail Safe) | | |
| F110 | Keypad Firmware Version | | Read Only | | | | |
| F111 | Relay Test | | 0 = Disabled, or 1 = Test (force) Relay 1 2 = Test (force) Relay 2 | 1 | 0 Disabled | | |

Warranty information.

1 Year Warranty: Phasetronics Inc., dba Motortronics, (hereinafter “Company”) warrants the **RX Series** products to be free from defects in material and/or workmanship for a period of one (1) year from the date of sale, or a maximum of 18 months from the date of manufacture (if no sales records are available) as indicated by the unit’s date code. The Company reserves the right to repair or replace any malfunctioning units or sub assemblies under warranty at the Company’ sole option. Warranty repairs may be performed at the Company’s facility, in the field by a factory authorized technician, or by the customer only with prior approval and at the specific direction of the Company’s Technical Services personnel. During the 1 year period, malfunctions will be dealt with by replacement of the unit.

Warranty Service Procedure:

In the event that warranty service becomes necessary, contact the distributor where the relay was purchased, or Motortronics Technical Services department directly at (727) 573-1819. Be prepared to provide the complete Model number, Serial Number, date and place of purchase. It is also helpful to know the date of initial commissioning. When a technician has determined the nature of the problem and it can be repaired by sending replacement parts or assemblies, they will require a purchase order for replacement parts and issue a Return Material Authorization (RMA) for the defective parts or assemblies. If any components or assemblies are received at the factory without the proper RMA documentation, the shipment(s) will be refused.

When the replacement parts are received and evaluated at the factory, any warranty determination will result in an offsetting credit being issued for the replacement parts already sent out. If the unit is not needed for operation, an alternative is to have the Technical Services representative provide an RMA for the components, and they will be evaluated and repaired at the factory, and returned. In either circumstance, freight/shipping costs are the responsibility of the purchaser.

Responsibility:

Company is not responsible for the misuse or misapplication of its products, intentional or otherwise. Improper application, installation, failure to provide safety devices or protective measures, or operation above the rated, and failure to properly maintain or service products are all beyond the control and responsibility of the Company. Under no circumstances shall the Company be liable for loss of profits, indirect, incidental, special, consequential or other similar damages arising out of the misuse, misapplication or failure to maintain the Company’s products.