

VMX Series

Compact Soft Starter

Ratings from 18 to 1250A (up to 1200HP)



by  **MOTORTRONICS**

- Integrated bypass contactor
- Advanced motor protection
- Narrow-width for MCC mounting
- Low-profile for use in pump panels
- Remote keypad mounting
- Unique built-in features

The control & protection you expect in an innovative soft starter design...

Flexibility of Control

Multiple ramp profiles, Pump-Flex™ Decel, process control timers and advanced motor protection make the VMX Series soft starter adaptable to a wide variety of AC motor applications... no need for add-on modules or costly auxiliary devices.

Compact packaging

has become critical in more and more electrical installations. The VMX Series meets this need without compromising features and ratings. By using a highly engineered packaging design and the latest generation microprocessor, all the control and protection features you need are in the VMX Series. Narrow and shallow dimensions are perfect for integrating the VMX Series into motor control centers (MCCs), pump control panels, and retrofit starter enclosures.

with the advantages of selectable control

Choose the ramping method that works best for your load...



Pumps, Fans, Blowers & Conveyors

- **Closed Loop Torque /Current (CLT™) Ramping**

provides a linear increase in output torque during acceleration.

It maximizes the available torque using an internal PID feedback loop, insuring a smooth, linear ramp up to full speed. Ideal for low pressure pumps where slight surges at the end of ramp may pose mechanical problems or on fans and mixers where blade warping can be an issue.

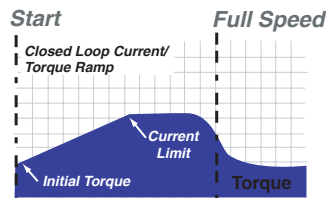

Compressors & Chillers

- **Voltage Ramp with Current Limit** for applications that need the smoothness of voltage ramping while maintaining the ability to start in limited power environments.

- For maximum motor power where the available power supply is severely limited, a **Current Limit/Current Step** start can be used.

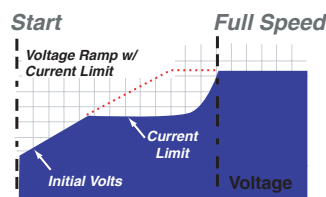

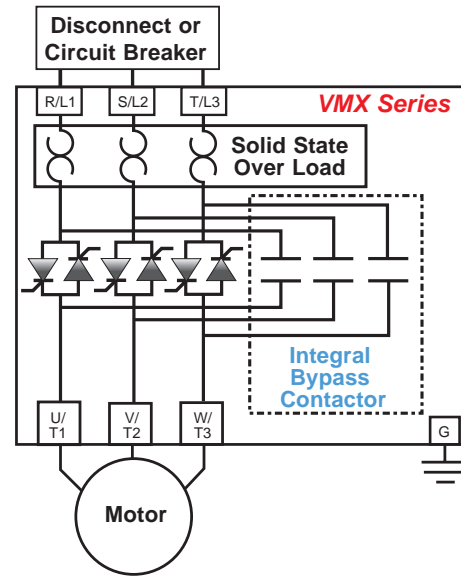

Integral Bypass Contactors are standard on all sizes and provide maximum efficiency of panel space while maintaining the Motortronics reputation for being able to soft start most any load. The *VMX Series* is the only fully integrated, compact, world-class design offering uncompromised power and control capabilities.

& unique built-in features

Eliminate the damaging effects of "Water Hammer"

A gradual reduction in the output torque of your pump motor is provided when a stop signal is initiated. When the motor output reaches a point where the check valve can be safely and gently closed, the Pump-Flex™ circuit automatically turns itself off.

Since no two pumps or pump applications are exactly the same, the flexible settings of Pump-Flex™ decel control allow you to tailor the output to precisely match your application requirements. No need for external timers or auxiliary controls.

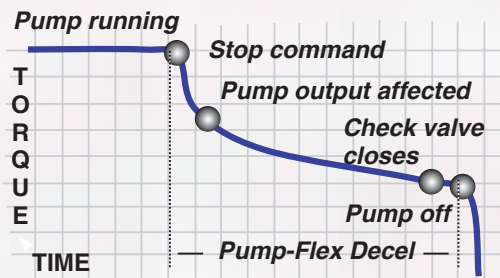

*Pump-Flex™ Decel...
Experience the Difference!*

When traditional electro-mechanical motor controls are used, motor torque is immediately lost when the power is turned off. The fluid that is flowing through the system, and the kinetic energy associated with it, immediately reverses direction. To prevent the reverse flow, a check valve typically is slammed shut, trapping the kinetic energy in the piping system. This shock wave, often referred to as "Water Hammer," is no longer a problem when you use Pump Flex™ decel control.

Minimize maintenance costs & downtime

By gradually reducing motor torque using Pump-Flex™ decel control, the potentially destructive pump output pressure is allowed to slowly dissipate in the system during the stopping process. Check valves close gently and other fluid system components including pipes, valves, flanges, couplings and hangers are no longer subjected to the shock and destructive potential of water hammer.

The VMX Series also includes...

Process Control Timer

Ideal for irrigation pumps when a specific amount of water needs to be pumped even if a power failure or a fault trip occurs during operation

- 24 hour/ 7 day Time Clock Controller
- Built-in time clock with selectable days-to-minute feature
- Batch Process Timer
- Run for a set time after starting, even after power outage

Metering

Elapsed time meter, run cycle counter, remaining lock-out time and fault history for maximum control and status of your pumps or processes.

World-class motor & system protection...

Separate Start & Run Overload Protection

Two programmable overload trip curves allow for the thermal capacity required to start the load, while providing more closely matched overload protection during the run time.

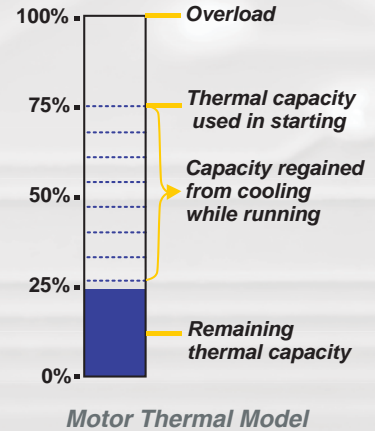

Real-Time Thermal Modeling

A dynamic thermal register continuously calculates motor operating temperature even when your motor is not running. Knows when the motor is cool enough for a successful restart.

- ✓ **Equipment ground fault trip and monitoring** (residual current method)
- ✓ **PTC thermistor input** for use on motors with embedded PTC temperature sensors

- ✓ **Current imbalance trip** and biasing of the thermal register
- ✓ **Phase loss protection** based on current and voltage
- ✓ **Electronic shear pin trip** (overcurrent) with trip delay

- ✓ **Load loss trip** (under current) with trip delay
- ✓ **Phase rotation protection**
- ✓ **Pre-start shorted load protection** checks for motor lead or winding damage

in a soft starter that is easy to install,

Unique, Compact Design

- Narrow width for MCC (motor control center) mounting
- Integrated bypass contactor
- Low profile for use in pump panels & other shallow enclosures
- Remote mount keypad capability
- Generous power terminal landing pads
- Pull apart control terminals for easy assembly & wiring
- Built-in features eliminate adding discreet devices
- Process control timers, metering, decel control, communications, and more

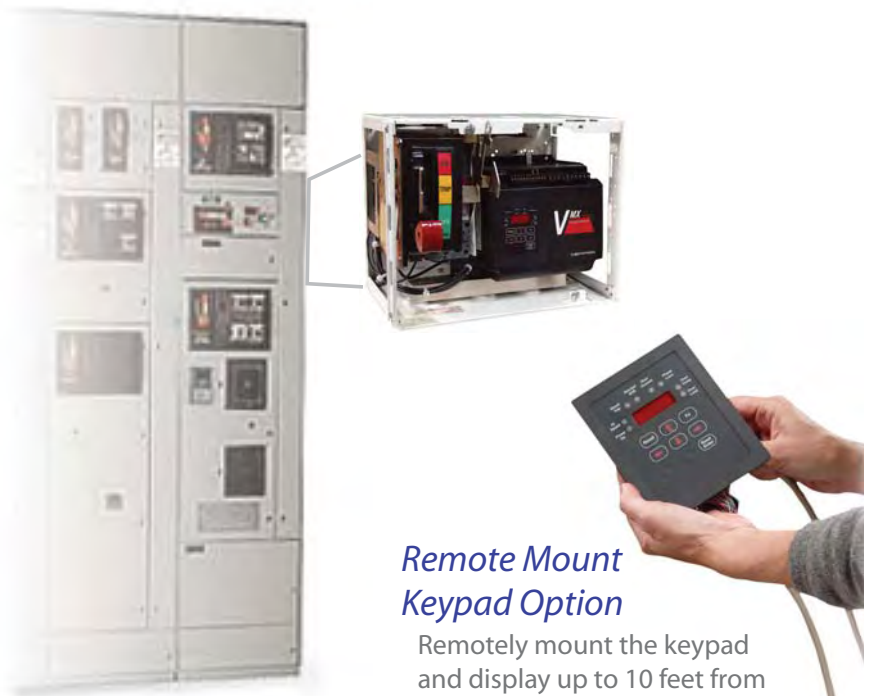

Remote Mount Keypad Option

Remotely mount the keypad and display up to 10 feet from the base unit, with NEMA 1 or NEMA 4/12 bezels

Retentive Thermal Memory

Remembers the motor thermal condition even in the event of a power loss or blackout. Extrapolates motor temperatures using a real-time clock.

Dynamic Reset Capacity

Overload will not reset until thermal capacity in the motor is sufficient for a successful restart. Starter learns and retains this information from previous starts.

Duty Cycle Protection

Back-spin timer ensures coast-down before restart

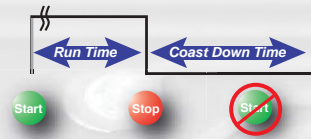

Minimum time between starts lock-out

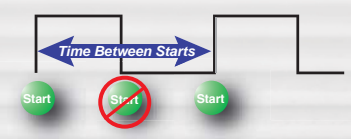

Starts-per-hour lockout to prevent motor damage

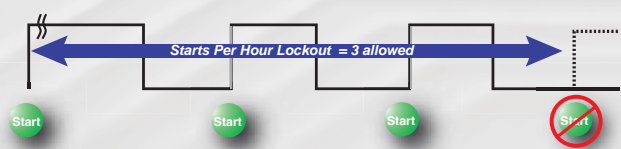

- ✓ **Running short circuit trip** acts like a high speed “electronic fuse”
- ✓ **Shorted SCR lockout**, defeatable for “must run” situations
- ✓ **Bypass discrepancy monitoring** ensures the Bypass Contactor closes

- ✓ **Over temperature trip** keeps track of heat sink temperature to avoid SCR damage
- ✓ **Shunt trip** detects welded contactor or multiple shorted SCRs (when used with shunt trip breaker)

- ✓ **Remaining thermal capacity** metering, to predict overloads
- ✓ **Metering** of A, B, C phase and ground fault currents

The features of a protection relay at no additional cost!

easy to wire & easy to use

Flexible Inputs & Outputs Put You in Control!

Easy access RS-485 comm port with Modbus RTU protocol built-in, no add-on communications module needed.

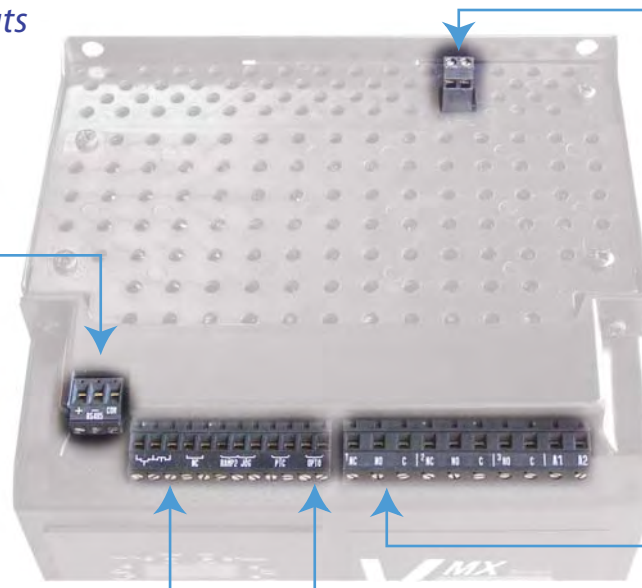

Emergency Bypass Input
simple contact closure allows for independent control of the Bypass contactor when emergency across-the-line starting is needed. (For heavy duty applications requiring full voltage, line start capability, see the VMX-HD Series).

Simple control wiring:
2 or 3 wire Start/Stop, N.C. Interlock, PTC /E-Stop, Jog and Dual Ramp, all operated at 24VDC for safety.

Dedicated fault triac with opto-isolation for PLC interface or connecting to an external relay.

3 dry contact relays:
2 FORM C and 1 FORM A, all fully programmable for over 30 functions including, Run, At Speed, End of Decel, nine other status indicators and 13 trip indicators, including an option to flash on certain faults.

Ratings

Standard Duty VMX Series Soft Starter with Integral Bypass

Model Number	Current Range (Min-Max)	Nominal Motor Rating (50/60 Hz)						
		NEMA				IEC		
		200V HP	230V HP	460V HP	575V HP	220V kw	380V kw	415V kw
VMX-18-BP	9 - 18	3 - 5	3 - 5	7.5 - 10	10 - 15	3 - 4	4 - 7.5	4 - 7.5
VMX-28-BP	14 - 28	7.5	7.5	15 - 20	20 - 25	5.5 - 7.5	11	11 - 15
VMX-39-BP	19 - 39	10	10	25	30	11	15 - 18.5	18.5
VMX-48-BP	24 - 48	15	15	30	40	-	22	22
VMX-62-BP	36 - 62	20	20	40	50 - 60	15 - 18.5	30	30
VMX-78-BP	39 - 78	25	25	50 - 60	75	22	37	37
VMX-92-BP	46 - 92	30	30	60	-	-	45	45
VMX-112-BP	56 - 112	-	40	75	100	30 - 37	55	55
VMX-150-BP	75 - 150	40	50	100	125	45	-	75
VMX-160-BP	80 - 160	50	60	125	150	-	75	90
VMX-210-BP	105 - 210	60	75	150	200	55	90 - 110	110
VMX-275-BP	138 - 275	75	100	200	250	75	132	132 - 160
VMX-361-BP	180 - 361	100 - 125	125 - 150	250 - 300	300	90 - 110	160 - 200	200
VMX-450-BP	225 - 450	150	175	350	400	132	250	250 - 275
VMX-550-BP	275 - 550	200	225	400 - 450	500	160	275 - 315	315
VMX-600-BP	300 - 600	200	250	500	600	-	-	-
VMX-862-BP	431 - 862	250	300	600	700	190	330	400
VMX-900-BP	450 - 900	300	350	700	800	220	440	500
VMX-1006-BP	503 - 1006	350	400	800	900	-	-	550
VMX-1250-BP	625 - 1250	400	500	1000	1200	-	-	700

Notes:

- Non-bypass units are available in ratings from 210A and above. Refer to Product Selection Guide for ratings & dimensions.
- For heavy duty applications, refer to VMX-HD Series.

Dimensions (in inches)

Model Number	H	W	D
VMX-18-BP thru VMX-48-BP	8.85	8.00	6.65
VMX-62-BP thru VMX-112-BP	14.00	8.00	6.65
VMX-150-BP thru VMX-160-BP	19.00	8.00	6.65
VMX-210-BP thru VMX-450-BP	28.50	12.50	9.10
VMX-550-BP thru VMX-600-BP	29.50	12.50	9.10
VMX-862-BP thru VMX-900-BP	44.25	25.50	11.86
VMX-1006-BP thru VMX-1250-BP	50.77	25.50	13.28

Note: Dimensions are for reference only and are subject to change. Contact factory for exact dimensions.

VMX - 160 - BP -

Max. Amps
18 - 1250 Amps

Enclosure
BP = Chassis w/ bypass
P = Chassis
E = NEMA 4/12
C = Combination starter

Control Power
Blank = 120 VAC
240 = 240 VAC



Specifications

Power Components

- 6 SCRs in inverse parallel pairs for full phase angle soft start control
- 1600V PIV rating on all units
- RC snubber for dv/dt protection of each SCR pair

Line Voltage Range

- 200 to 600 VAC, 3 phase +10% -15% on all units, 50/60Hz

Current Ratings

- 18 - 1250A depending on unit selection
- Range of each unit is 50-100% of maximum current rating based on 1.0 service factor

AC Supply Voltage

- User supplied 120VAC +10% -15% tolerance, 60Hz
- Optional 240VAC 50Hz control available

Overload Capacity (% of motor FLA)

- 600% for 10 seconds, 350% for 30 seconds
- 100% of Max Amp rating continuous per UL

Bypass Contactor

- Standard on all units
- Non-bypassed model available 210A & above (refer to product selection guide)
- Heavy Duty (Across-the-Line) rated models available (refer to *VMX-HD Series* in product selection guide)

Start/Stop Control Choices

- 2-wire Run-Stop using dry contacts
- 3-wire Start/Stop with built-in seal in contact
- N.C. Interlock input (dry contact) for remote devices

Ramp Control Choices (4 built-in)

- Voltage Ramp
- Voltage Ramp with Current Limit
- CLT[®] Closed Loop Torque Ramp (Current Ramp)
- Current Step (current limit only)
- Ramp times adjustable 1 - 120 seconds
- Current Limit adjustable 200 - 600% of FLA

Dual Ramps

- Select via dry contact closure between any combinations of the above

Certifications



Jog

- Dry contact closure selects a non-ramping Jog function at an adjustable torque

Kick Start

- 10 - 100% starting torque for 0.1 - 2 seconds

Pump-Flex™ Deceleration Ramp

- Fully adjustable to match field conditions:
 - Begin Decel setting, 0 - 100% of line voltage
 - Decel ramp time, 1 - 60 seconds
 - End Decel setting (Off), 0 - 1% of Begin setting

Restart Delay Timer (Sequential Start Delay)

- Programmable time delay 1 - 999 seconds after loss of control power for staggered restarts

Time Clock Controller

- 24 hour/7 day time clock to provide automatic start
- Up to 7 start events per day
- Select operation from 1 through 7 days per week
- Run time determined by process control timer

Process Control Timer (choice of either)

- Minimum Run (Batch) Timer
 - 1 - 999 minutes
 - Runs until time expires, resets only if expired
 - Resumes and finishes if stopped or power is lost

Permissive Run Timer

- 1 - 999 minutes
- Only allows operation during active run time

RS-485 Serial Communications

- Up to 247 starters per link
- Modbus RTU protocol built-in
- Full programming over the serial link
- Programmable remote starter control

Operator Interface

- Tactile feedback keypad
- Easy to read LED display
- Run and fault status indicators



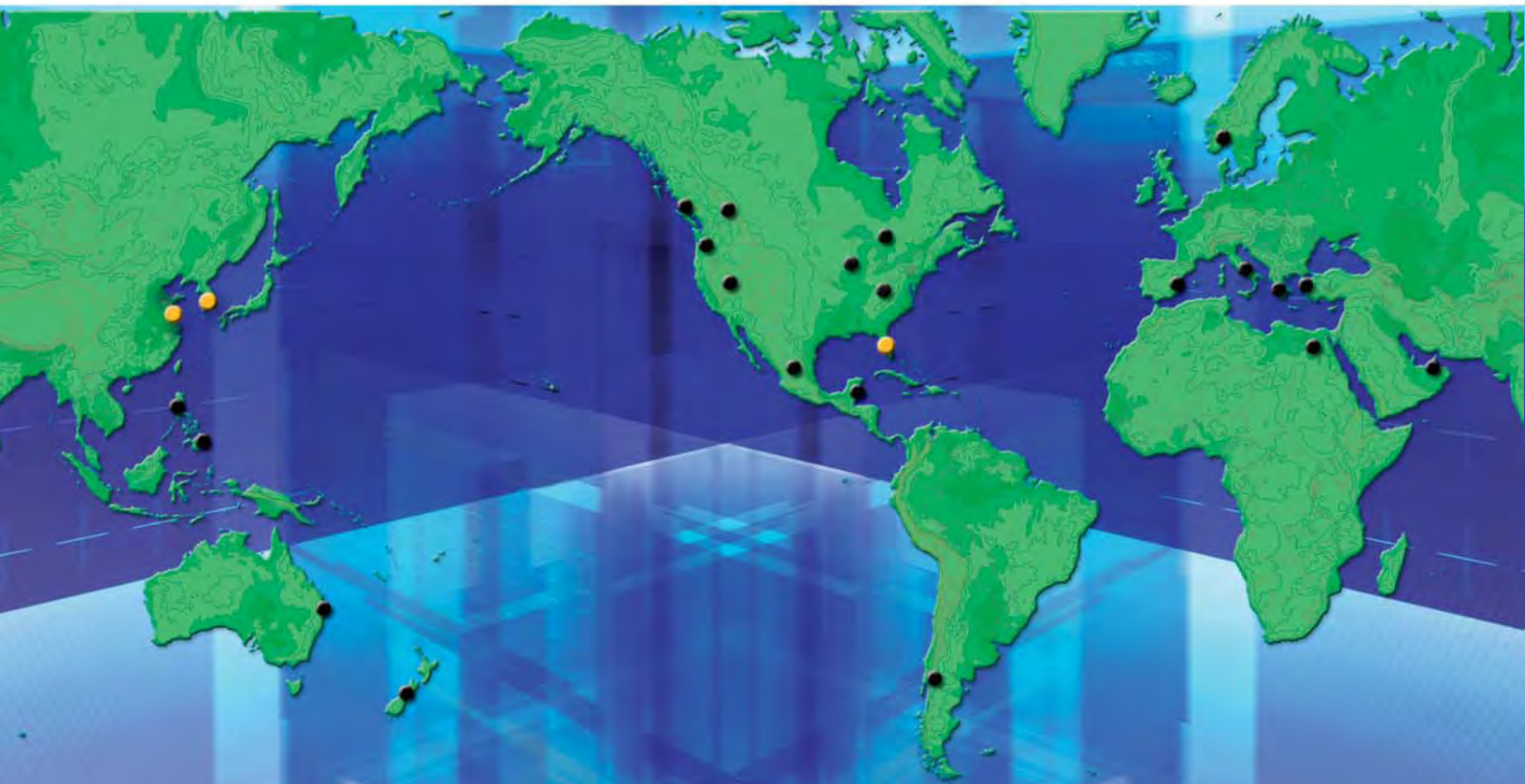

World Class Products & Service

by  **MOTORTRONICS**

Corporate Headquarters

Motortronics/Phasetronics
1600 Sunshine Drive
Clearwater, Florida 33765 USA
Tel: 727.573.1819 or 888.767.7792
Fax: 727.573.1803 or 800.548.4104
E-mail: motorctrl@aol.com
www: motortronics.com

International Locations

Motortronics Int'l Korea Co Ltd
601, Daeryung Techno Tower 6-cha
Gasan-dong, Geumcheon-gu
Seoul, Korea (153-774)
Tel: 82-2-867-5806-8
Fax: 82-2-867-6004
www: motortronics-korea.com

M & P Machinery & Electronics Control

113 Zaoshan Road
Qingdao, China 266100
Tel: 86-532-87660633
Fax: 86-532-87660733
www: mp-cn.com